

en

OWNER'S MANUAL

fr

MANUEL DE L'UTILISATEUR

es

MANUAL DEL PROPIETARIO

pt

MANUAL DO PROPRIETÁRIO

zh

用户手册

ru

РУКОВОДСТВО ПОЛЬЗОВАТЕЛЯ

TOHATSU

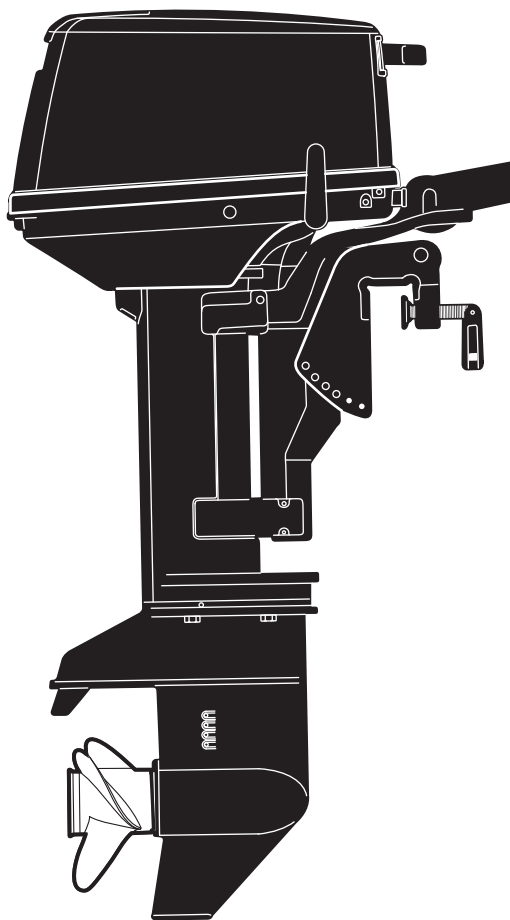

M 6B
M 8B
M 9.8B

OB No.003-11029-EAF1

OWNER'S MANUAL

 TOHATSU

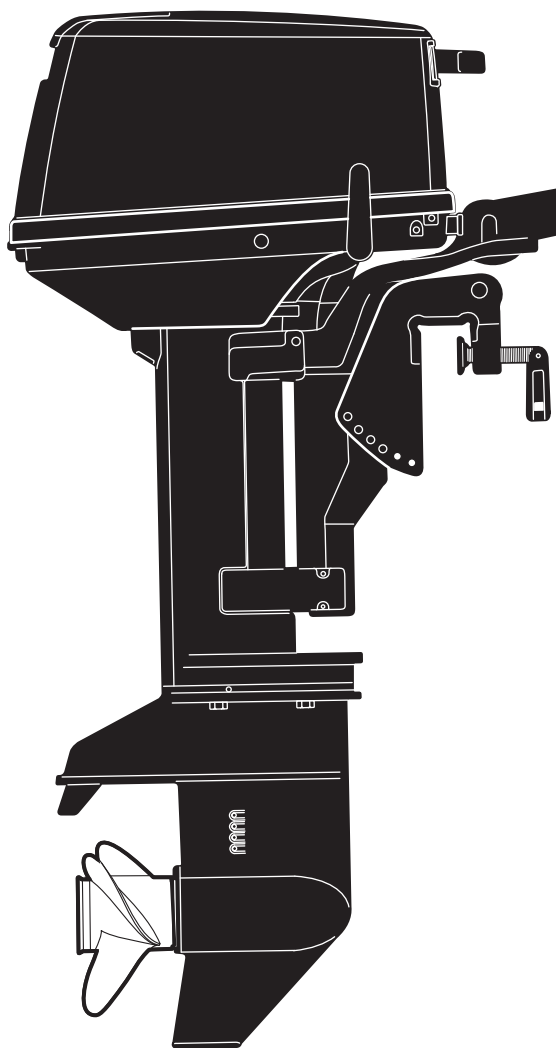

M 6B
M 8B
M 9.8B

OB No.003-11029-EAF1

ENOM00001-0

 **READ THIS MANUAL BEFORE USING THE OUTBOARD MOTOR. FAILURE TO FOLLOW THE INSTRUCTIONS AND SAFETY PRECAUTIONS IN THIS MANUAL CAN RESULT IN SERIOUS INJURY OR DEATH. KEEP THIS MANUAL IN A SAFE LOCATION FOR FUTURE REFERENCE.**

Copyright © 2016 Tohatsu Corporation. All rights reserved. No part of this manual may be reproduced or transmitted in any form or by any means without the express written permission of Tohatsu Corporation.

YOUR TOHATSU OUTBOARD MOTOR

ENOM00006-A

To You, Our Customer

Thank you for selecting a TOHATSU outboard motor. You are now the proud owner of an excellent outboard motor that will service you for many years to come.

This manual should be read in its entirety and the inspection and maintenance procedures described later in this manual should be followed carefully. Should a problem arise with the outboard motor, please follow the troubleshooting procedures listed at the end of this manual. If the problem persists, contact an authorized TOHATSU service shop or dealer.

Please always keep this manual together with the outboard motor as a reference to everyone who uses the outboard motor. If the outboard motor is resold, make sure the manual is passed on to the next owner.

We hope you will enjoy your outboard motor and wish you good luck in your boating adventures.

TOHATSU CORPORATION

ENOM00003-0

PRE-DELIVERY CHECK

Be sure that the product has been checked by an authorized TOHATSU dealer before you take delivery.

ENOM00005-A

Serial Number

In the space below, please record the outboard motor's serial number (indicated both on the bottom cowl and on the cylinder block). The serial number will be needed when ordering parts, and when making technical or warranty inquiries.

Serial Number:

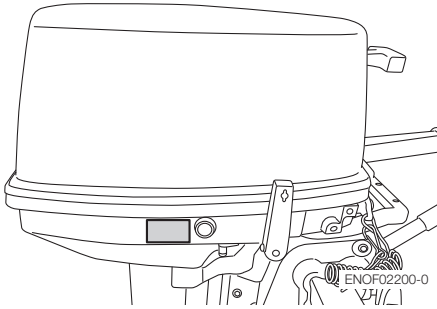

Serial Number:

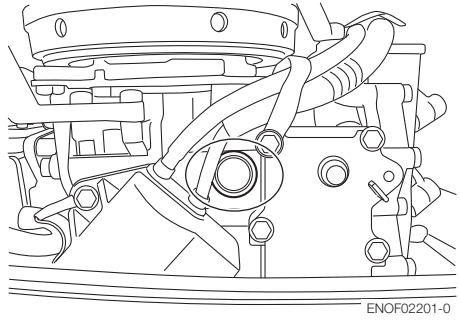

Date of purchase:

ENOM00007-0

NOTICE: DANGER/WARNING/CAUTION/Note

Before installing, operating or otherwise handling your outboard motor, be sure to thoroughly read and understand this Owner's Manual and carefully follow all of the instructions. Of particular importance is information preceded by the words "DANGER," "WARNING," "CAUTION," and "Note." Always pay special attention to such information to ensure safe operation of the outboard motor at all times.

ENOW00001-0

 **DANGER**

Failure to observe will result in severe personal injury or death, and possibly property damage.

ENOW00002-0

 **WARNING**

Failure to observe could result in severe personal injury or death, or property damage.

ENOW00003-0

 **CAUTION**

Failure to observe could result in personal injury or property damage.

ENON00001-0

Note

This instruction provides special information to facilitate the use or maintenance of the outboard motor or to clarify important points.

CONTENTS

1. GENERAL SAFETY INFORMATION	10
2. SPECIFICATIONS	12
3. PARTS NAME	14
4. LABEL LOCATIONS	17
5. INSTALLATION	20
1. Mounting the outboard motor on boat	20
2. Remote control device installation	22
3. Battery installation	22
6. PRE-OPERATING PREPARATIONS	24
1. Fuel handling	24
2. Fuel filling	25
3. Engine oil recommendation	26
4. Break-In	28
7. ENGINE OPERATION	29
Before starting	29
1. Fuel feeding	29
2. Starting the engine	30
3. Warming up the engine	34
4. Forward, reverse, and acceleration	34
5. Stopping the engine	36
6. Steering	37
7. Trim angle	37
8. Tilt up and down	39
9. Shallow water operation	40
8. REMOVING AND CARRYING THE OUTBOARD MOTOR	42
1. Removing the outboard motor	42
2. Carrying the outboard motor	42
3. Trailering	43
9. ADJUSTMENT	44
1. Steering friction	44
2. Throttle grip friction	44
3. Trim tab adjustment	44
10. INSPECTION AND MAINTENANCE	46
1. Daily Inspection	47
2. Periodic Inspection	51
3. Off-season storage	59
4. Pre-season check	61
5. Submerged outboard motor	61
6. Cold weather precautions	62
7. Striking underwater object	62
8. Auxiliary outboard motor operation	62

11. TROUBLESHOOTING	63
12. TOOL KIT AND SPARE PARTS	65
13. PROPELLER TABLE	66

INDEX

1 GENERAL SAFETY INFORMATION	1
.....	
2. SPECIFICATIONS	2
.....	
3. PARTS NAME	3
.....	
4. LABEL LOCATIONS	4
.....	
5. INSTALLATION	5
.....	
6. PRE-OPERATING PREPARATIONS	6
.....	
7. ENGINE OPERATION	7
.....	
8. REMOVING AND CARRYING THE OUTBOARD MOTOR	8
.....	
9. ADJUSTMENT	9
.....	
10.INSPECTION AND MAINTENANCE	10
.....	
11.TROUBLESHOOTING	11
.....	
12.TOOL KIT AND SPARE PARTS	12
.....	
13.PROPELLER TABLE	13
.....	

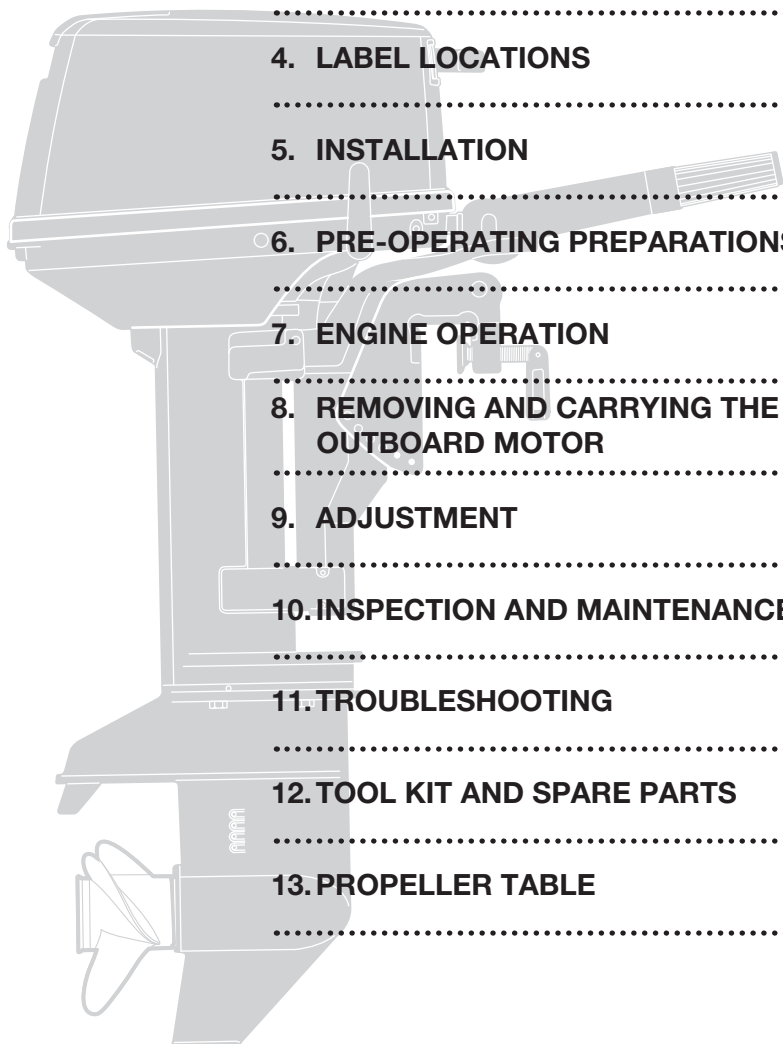

GENERAL SAFETY INFORMATION

ENOM00009-0

SAFE OPERATION OF BOAT

As the operator/driver of the boat, you are responsible for the safety of those aboard and those in other boats around yours, and for following local boating regulations. You should be thoroughly knowledgeable on how to correctly operate the boat, outboard motor, and accessories. To learn about the correct operation and maintenance of the outboard motor, please read through this manual carefully.

It is very difficult for a person standing or floating in the water to take evasive action should he or she see a power boat heading in his/her direction, even at a slow speed. Therefore, when your boat is in the immediate vicinity of people in the water, the outboard motor should be shifted to neutral and shut off.

ENOW00005-0

WARNING

SERIOUS INJURY IS LIKELY IF A PERSON IN THE WATER MAKES CONTACT WITH A MOVING BOAT, GEAR HOUSING, PROPELLER, OR ANY SOLID DEVICE RIGIDLY ATTACHED TO A BOAT OR GEAR HOUSING.

ENOM00008-A

EMERGENCY STOP SWITCH

The Emergency Stop Switch will stall the outboard motor when the stop switch lanyard is pulled off. This stop switch lanyard has to be attached to the operator of the outboard motor to minimize or prevent injuries from the propeller in case the operator falls overboard.

It is operator's responsibility to use the Emergency Stop Switch Lanyard.

ENOW00004-A

WARNING

Accidental activation of the Emergency Stop Switch (such as the tether being pulled out in heavy seas) could cause passengers to lose their balance and even fall overboard, or it could result in loss of power in heavy seas, strong currents, or high winds. Loss of control while mooring is another potential hazard.

To minimize accidental activation of the Emergency Stop Switch, the 500 mm (20 inch.) stop switch lanyard is coiled and can be extended to a full 1300 mm (51 inch.).

ENOM00800-A

PERSONAL FLOATATION DEVICE

As the operator/driver and passenger of the boat, you are responsible to wear a PFD (Personal Floatation Device) while on the boat.

ENOM00010-0

SERVICING, REPLACEMENT PARTS & LUBRICANTS

We recommend that only an authorized service shop perform service or maintenance on this outboard motor. Be sure to use genuine parts, genuine lubricants, or recommended lubricants.

ENOM00011-A

MAINTENANCE

As the owner of this outboard motor, you should be acquainted with correct maintenance procedures following maintenance section of this manual (See page 46). It is the operator's responsibility to perform all safety checks and to ensure that all lubrication and maintenance instructions are complied with for safe operation. Please comply with all instructions concerning lubrication and maintenance. You should take the engine to an authorized dealer or service shop for periodic inspection at the prescribed intervals.

Correct periodic maintenance and proper care of this outboard motor will reduce the chance of problems and limit overall operating expenses.

Carbon Monoxide Poisoning Hazard

Exhaust gas contains carbon monoxide, a colorless and odorless gas which can be fatal if inhaled for any length of time.

Never start or operate the engine indoors or in any space which is not well ventilated.

Gasoline

Gasoline and its vapors are very flammable and can be explosive. Use extreme care when handling gasoline. You should be thoroughly knowledgeable on how to correctly handle gasoline by reading this manual.

SPECIFICATIONS

ENOM00810-B

MODEL FEATURE

Model		M6B	M8B	M9.8B	
Type		MF	MF	MF	EF
Transom heights	S	●	●	●	●
	L	●	●	●	●
	UL			●	
Tiller Handle		●	●	●	●
Remote Control		(●)*1	(●)*1	(●)*1	(●)*1
Manual tilt		●	●	●	●

*1 Option

ENOM00811-C

MODEL NAME EXAMPLE

M9.8B EFL

M	9.8	B	E	F	L
Model description	Horse power	Product generation	Starter system	Steering system	Shaft length
M(X)= Two stroke F= Four stroke D= Two stroke DI	-	A and up	E= Electrical start M= Manual start	P=Remote control (Pleasure) F=Tiller handle (Fisher)	S= Short 15 in L= Long 20 in UL= Ultra long 25 in

ENOM01500-0

6B MF, 8B MF, 9.8B MF, 9.8B EF

2

Item	MODEL	6B MF	8B MF	9.8B MF	9.8B EF
Overall Length	mm (in)	793 (31.2)			
Overall Width	mm (in)	320 (12.6)			
Overall Height	S mm (in)	996 (39.2)			
	L mm (in)	1123 (44.2)			
	UL mm (in)	1250 (49.2)			
Transom Height	S mm (in)	435 (17.2)			
	L mm (in)	562 (22.2)			
	UL mm (in)	689 (27.1)			
Weight	S kg (lb)	26 (57)			29 (64)
	L kg (lb)	27 (60)			30 (66)
	UL kg (lb)	28 (62)			-
Output	kW (ps)	4.4 (6)	5.9 (8)	7.2 (9.8)	
Max. Operating Range	rpm	4500-5500		5000-6000	
Trolling Speed in Forward Gear	rpm	750			
Idle Speed in Neutral Gear	rpm	950			
Number of Cylinder		2			
Bore x Stroke	mm (in)	50 x 43 (1.97 x 1.69)			
Piston Displacement	mL (Cu in)	169 (10.3)			
Exhaust System		Through hub exhaust			
Cooling System		Forced water cooling			
Lubrication System		Engine Oil Mixed Gasoline			
Starting System		Manual			Electric starter motor*
Ignition System		Flywheel Magneto C.D. Ignition			
Spark Plug		BPR7HS-10			
Trim Position		6			
Fuel		Unleaded regular gasoline : Pump posted 87 Octane (research octane rating of 91)			
Fuel Tank Capacity	L (US gal)	12 (3.17)			
Engine Oil		Genuine motor oil or recommended one (TCW-III)			
Fuel : Engine Oil Mixing Ratio		Unleaded Gasoline 50 : Genuine 2-stroke Engine Oil 1			
Gear Oil	mL (fl.oz)	Genuine Gear Oil or API GL5, SAE #80 to #90, approx. 320 (10.8)			
Gear Reduction Ratio		2.08 (13 : 27)			

Remark : Specifications subject to change without notice.

* : with manual

Tohatsu outboard is power rated in accordance with ISO8665 (propeller shaft output).

PARTS NAME

ENOM01501-0

6B MF, 8B MF, 9.8B MF

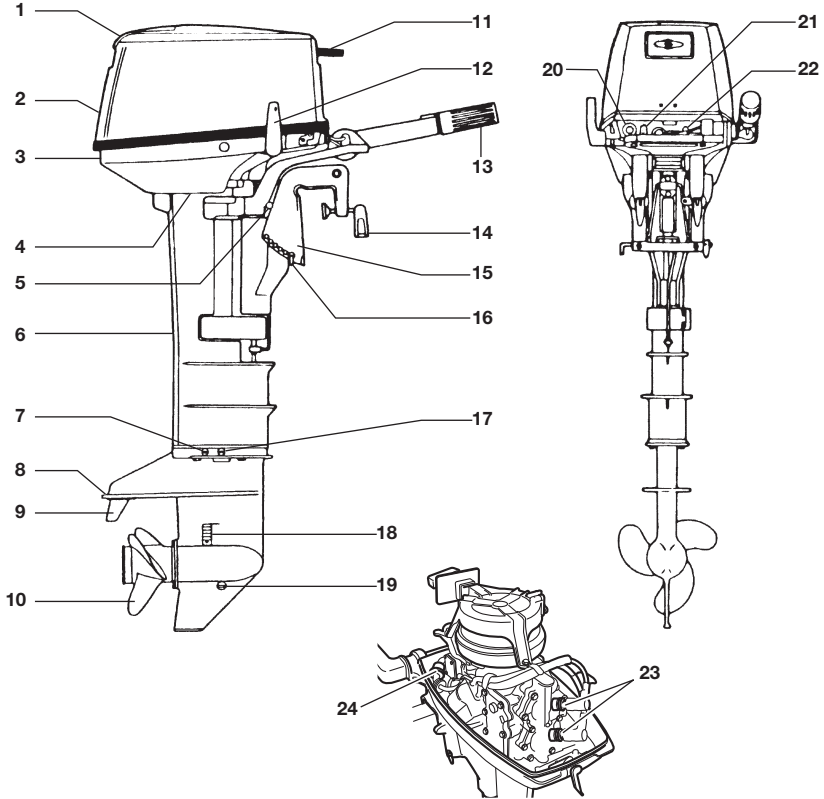

- 1 Tilt Handle
- 2 Top Cowl
- 3 Bottom Cowl
- 4 Cooling Water Check Port
- 5 Tilt Stopper
- 6 Drive Shaft Housing
- 7 Water Plug
- 8 Anti-Ventilation Plate
- 9 Anode / Trim Tab
- 10 Propeller

- 11 Starter Handle
- 12 Shift Lever
- 13 Throttle Grip
- 14 Clamp Screw
- 15 Clamp Bracket
- 16 Thrust Rod
- 17 Oil Plug (Upper)
- 18 Water Inlet
- 19 Oil Plug (Lower)
- 20 Stop Switch

- 21 Choke Knob
- 22 Fuel Connector
- 23 Spark Plug
- 24 Fuel Filter

ENOF02203-0

ENOM01502-0

9.8B EF

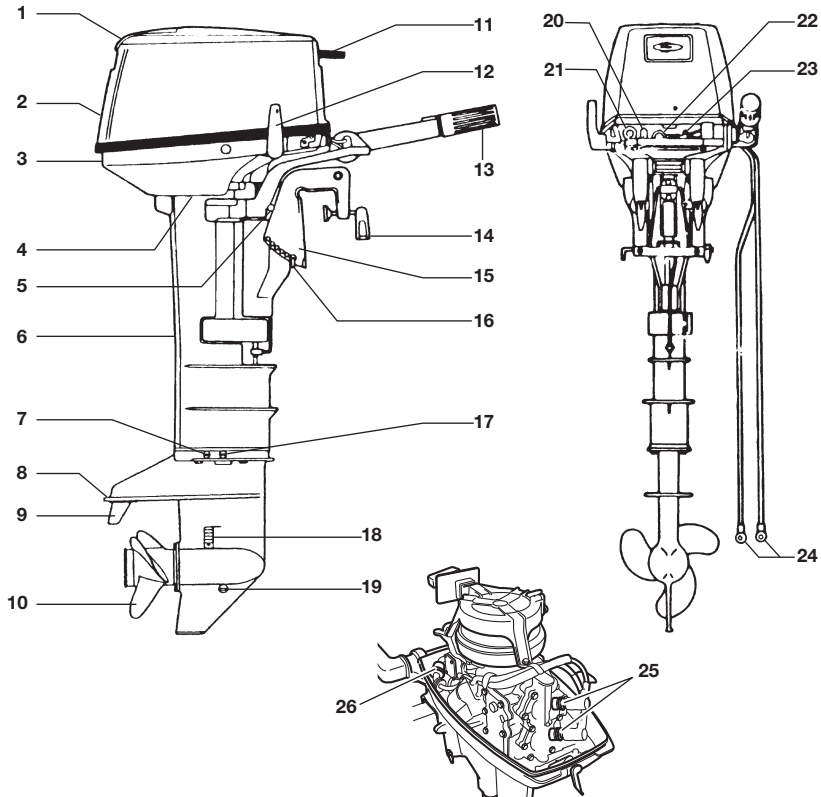

- 1 Tilt Handle
- 2 Top Cowl
- 3 Bottom Cowl
- 4 Cooling Water Check Port
- 5 Tilt Stopper
- 6 Drive Shaft Housing
- 7 Water Plug
- 8 Anti-Ventilation Plate
- 9 Anode / Trim Tab
- 10 Propeller

- 11 Starter Handle
- 12 Shift Lever
- 13 Throttle Grip
- 14 Clamp Screw
- 15 Clamp Bracket
- 16 Thrust Rod
- 17 Oil Plug (Upper)
- 18 Water Inlet
- 19 Oil Plug (Lower)
- 20 Choke Knob

- 21 Stop Switch
- 22 Main Switch
- 23 Fuel Connector
- 24 Battery Cord
- 25 Spark Plug
- 26 Fuel Filter

ENOF02204-0

ENOM00822-0

Remote control box & Fuel tank

3

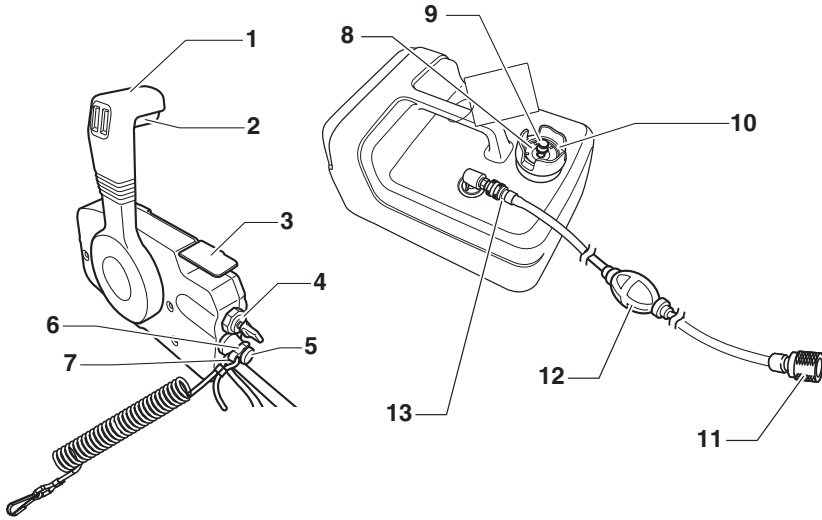

ENOF02103-0

- 1 Control Lever
- 2 Neutral lock arm
- 3 Free throttle lever
- 4 Main switch
- 5 Stop switch
- 6 Stop switch lock
- 7 Stop switch lanyard

- 8 Fuel gauge
- 9 Air vent screw
- 10 Fuel tank cap
- 11 Fuel connector (Engine side)
- 12 Primer bulb
- 13 Fuel connector (Fuel tank side)

■ LABEL LOCATIONS

ENOM00019-A

Warning label locations

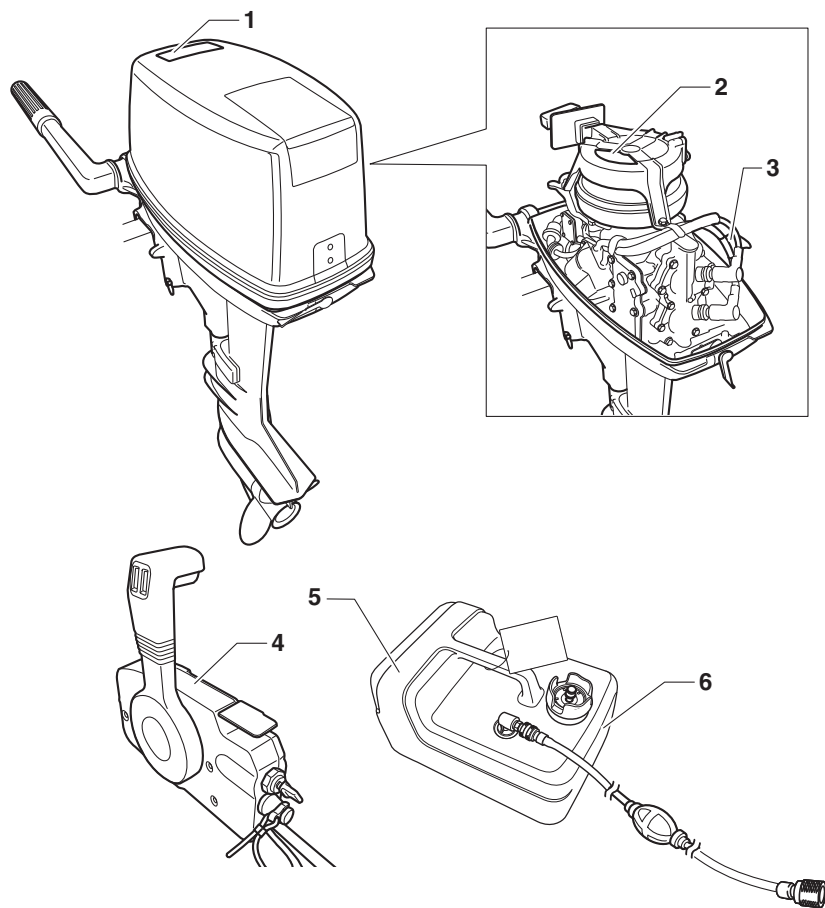

4

ENOF02206-0

18 LABEL LOCATIONS

1. Warning label regarding owner's manual, top cowl and engine stop switch.



ENOF00005-W

2. Warning regarding rotating object.



ENOF00005-X

3. Warning regarding high voltage.

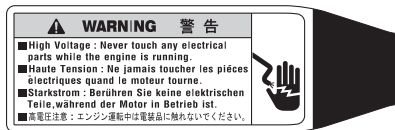

3C8-72181-0B

4. Warning label regarding engine stop switch.



ENOF00008-0

5. Warning regarding gasoline (See page 24).



REMOVE FROM BOAT
FOR FILLING

ENOF00005-S

6. Warning regarding gasoline (See page 24).



ENOF00005-L

ENOM01001-0

Serial number label locations

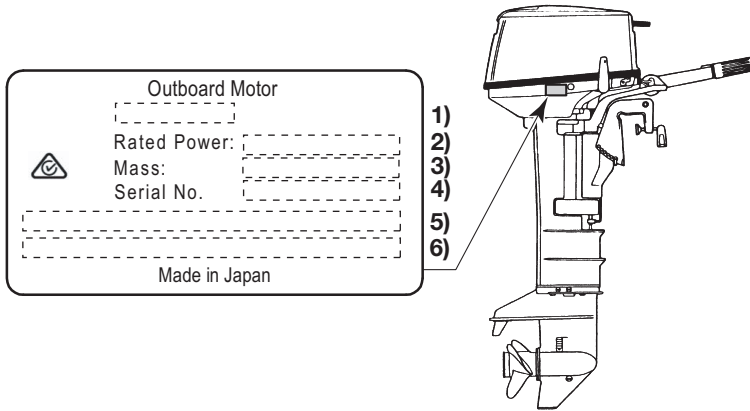

4

1. Model code(Model name)
2. Rated power
3. Dry mass weight
4. Serial No.
5. Manufacture name
6. Manufacture address

ENOF02207-0

INSTALLATION

ENOM00024-B

1. Mounting the outboard motor on boat

ENOW00006-0

WARNING

Most boats are rated and certified in terms of their maximum allowable horsepower, as shown on the boat's certification plate. Do not equip your boat with an outboard motor that exceeds this limit. If in doubt, contact your dealer.

Do not operate the outboard motor until it has been securely mounted on the boat in accordance with the instructions below.

5

ENOW00009-0

WARNING

- Mounting the outboard motor without following this manual can lead to unsafe conditions such as poor maneuverability, lack of control or fire.
- Loose clamp screws and/or mounting bolts can lead to the release or displacement of the outboard motor, possibly resulting in lost of control and/or serious personal injury. Be sure that fasteners are tightened to the specified torque (30 Nm (3.0 kgf) 13 ft-lb). Check the fasteners for tightness from time to time.
- Be sure to use outboard mounting fasteners included in the outboard motor package or their equivalents in terms of size, material, quality and strength. Tighten fasteners to the specified torque (30 Nm (3.0 kgf) 13 ft-lb). Test cruise to check if fasteners are tightened securely.
- Outboard motor mounting must be performed by trained service person(s) using lift or hoist with sufficient capacity.

Keep the outboard motor in a vertical position when mounting.

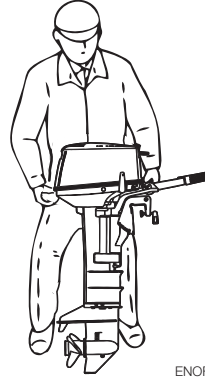

ENOF02208-0

ENOM00025-0

Position ... Above keel line

Set engine at center of boat.

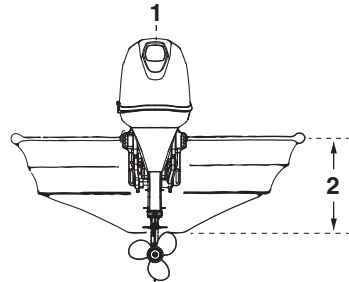

ENOF01141-0

1. Center of boat
2. Boat transom

ENOM00026-0

Transom matching

Be sure that the anti ventilation plate of the outboard motor is 30–50 mm (1.2–2 in) below the bottom of hull.

If the above condition cannot be met due to the shape of the bottom of your boat, please consult your authorized dealer.

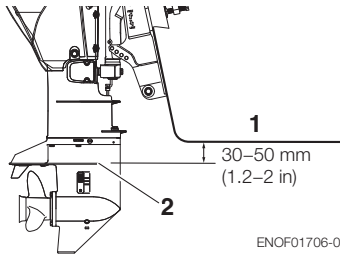

- 1. Bottom of hull
- 2. Anti ventilation plate

ENOW00007-0

CAUTION

- Before beginning the running test, check that the boat with maximum capacity loading floats on the water in a proper attitude. Check the position of water surface on the driveshaft housing. If the water surface is near the bottom cowling, in high waves, water may enter the engine cylinders.
- Incorrect outboard motor mounting height or existence of underwater object(s), such as hull bottom design, bottom surface conditions or underwater accessories, can cause water spray possibly reaching the engine through an opening of the bottom cowling during cruising. Exposing the engine to such conditions for extended periods can lead to severe engine damage.

ENOM00830-A

Mounting bolts

Manual tilt type

1. To attach the outboard motor to the boat, tighten the clamp screws by turning their handles. Also, use the bolts to secure the outboard motor brackets on transom board.
- Secure the outboard motor with a rope to prevent loss overboard.

ENON00002-0

Note

A rope is not included in the standard accessories.

5

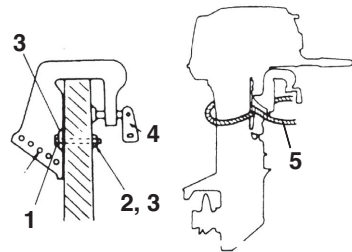

- 1. Bolt (8 × 85)
- 2. Nut
- 3. Washer
- 4. Clamp screw
- 5. Option

ENON00003-0

Notes

1. Apply sealing agent, such as silicone sealed between the bolts and the transom board holes before tightening the bolts.
2. Be sure to tighten the mounting bolt nuts to the specified torque.
(30 Nm (3.0 kgf) 13 ft-lb)

ENOM00840-0

2. Remote control device installation (Option)

ENOW00850-0

Remote control box location

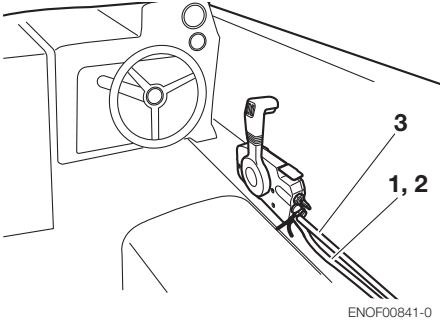

1. Shift cable
2. Throttle cable
3. Remote control stop cord

Install the remote control box in a position where it is easy to reach and operate the controls.

Make sure there are no obstacles that can interfere with the operation of the remote control cable.

ENOW00850-0

Remote control cable length

ENOW00100-A

CAUTION

Be careful not to loop the remote control cables to a diameter of 406 mm (16 inches) or less. Otherwise, it affects the service life of the cable.

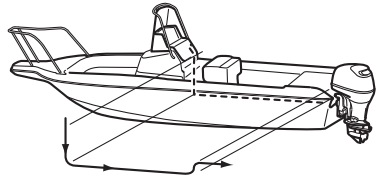

ENOF00842-0

Measure the distance from the remote control box to the outboard motor where the remote control cable should be routed. Prepare a cable that is 300-450mm (11.8-17.7in) longer than the measured distance. Temporarily pull the cable along the intended cable route to check its length is sufficient.

Connect the remote control cable to the engine, then run the cable to the remote control box, making sure it is not sharply bent, too taut and free from obstructions that could interfere with steering.

ENOM00029-A

3. Battery installation

ENOW00012-0

WARNING

Battery electrolyte contains sulfuric acid and thus is hazardous, causing a burn if it comes in contact with your skin, or poisonous if swallowed.

Keep battery and electrolyte away from reach of children

When handling the battery, be sure to:

- Read all warnings shown on the battery case
- Prevent electrolyte from coming in contact with any part of your body. Contact can cause serious burn or, if it comes in

contact with your eye, loss of sight. Use safety glasses and rubber gloves.

In case battery electrolyte comes in contact with:

- Skin, flush thoroughly with water.
- Eye, flush thoroughly with water, and then seek immediate medical treatment.

In case battery electrolyte is swallowed:

- Seek immediate medical treatment.

ENOW00013-A

WARNING

Battery generates explosive hydrogen gas.

Be sure to:

- Charge the battery in a well-ventilated place.
- Place the battery away from any source of fire, sparks and open flames such as burners or welding equipment.
- Do not smoke near the battery when the battery is charging.
- Do not charge the battery when the electrolyte level is low. Otherwise, the battery will be damaged and may cause malfunction.

ENOW00014-0

CAUTION

- Make sure that the battery leads do not get stuck between the outboard motor and boat when turning, etc.
- The starter motor may fail to operate if the leads are incorrectly connected.
- Be sure to correctly connect the (+) and (-) leads. If not, the charging system will be damaged.
- Do not disconnect the battery leads from battery while the engine is operating, the electrical parts could be damaged.
- Always use a fully charged battery.

ENOW00015-0

CAUTION

Do not use a battery that is not recommended. Use of a battery not recommended can lead to poor performance of, and/or damage to, the electrical system.

ENON00006-A

Note

Recommended battery: 12V 40AH/5HR, 350 (Cold Cranking Amps (CCA), In case of cold whether: 12V 70AH/5HR (650CCA)) Specifications and features of batteries vary among the manufacturers. Consult the manufacturer for details.

* The battery should be purchased separately and is not supplied with the outboard motor.

1. Place the battery box in a convenient position away from possible water spray. Securely fasten both the box and the battery so they do not shake loose.
2. Connect the positive lead (+) to the positive terminal (+) of the battery, and then connect the negative lead (-). When disconnecting the battery always remove the negative lead (-) first. After connecting the positive terminal (+), securely place a cap on it to prevent short circuits.

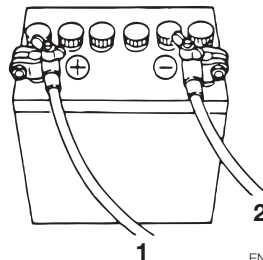

ENOF00022-0

1. Battery cord (red)
2. Battery cord (black)

PRE-OPERATING PREPARATIONS

ENOM00030-A

1. Fuel handling

ENOW000017-0

CAUTION

Use of improper gasoline can damage your engine. Engine damage resulting from the use of improper gasoline is considered misuse of the engine, and damage caused thereby will not be covered under the limited warranty.

ENOM00031-A

FUEL RATING

TOHATSU engines will operate satisfactorily when using a major brand of unleaded gasoline meeting the following specifications:

USA and Canada — having a posted pump Octane Rating of 87 (R+M)/2 minimum. Premium gasoline (92 [R+M]/2 Octane) is also acceptable. Do not use leaded gasoline.

Outside USA and Canada — Use unleaded gasoline with declared octane rating of 91 RON or over. Use of premium gasoline of 98 RON is also allowed.

ENOM00032-A

GASOLINES CONTAINING ALCOHOL

The fuel system components on your TOHATSU engine will withstand up to 10% ethyl alcohol (hereinafter referred to as the "ethanol"), content in the gasoline. But if the gasoline in your area contains ethanol, you should be aware of certain adverse effects that can occur. Increasing the percentage of ethanol in the fuel can also worsen these adverse effects. Some of

these adverse effects are caused because the ethanol in the gasoline can absorb moisture from the air, resulting in a separation of the water/ethanol from the gasoline in the fuel tank.

These may cause increased:

- Corrosion of metal parts
- Deterioration of rubber or plastic parts
- Fuel permeation through rubber fuel lines
- Starting and operating difficulties

If the use of gasoline containing alcohol is inevitable, or presence of alcohol is suspected in the gasoline, it is recommended to add a filter that has water separating capability, and check the fuel system for leaks and mechanical parts for corrosion and abnormal wear more frequently.

And, in case any of such abnormality is found, discontinue the use of such gasoline and contact our dealer immediately.

If the outboard motor will only be used infrequently, please see the remarks on fuel deterioration in the STORAGE chapter (P 56) for additional information.

ENOW00020-0

CAUTION

When operating a TOHATSU engine on gasoline containing alcohol, storage of gasoline in the fuel tank for long periods should be avoided. Long periods of storage, common to boats, create unique problems. In cars, alcohol blend fuels normally are consumed before they can absorb enough moisture to cause trouble, but boats often sit idle long enough for phase separation to take place. In addition, internal corrosion may take place during stor-

age if alcohol has washed protective oil films from internal components.

ENOW00018-0

WARNING

Fuel leakage can cause fire or explosion, potentially leading to severe injury or loss of life. Every fuel system part should be checked periodically, and especially after long term storage, for fuel leak, change of hardness of rubber, expansion and/or corrosion of metals. In case any indication of fuel leakage or degradation of fuel part is found, replace relevant part immediately before continuing operation.

ENOM00043-B

2. Fuel filling

ENOW00019-0

WARNING

Do not fill the fuel tank over capacity. The rise of gasoline temperature may cause gasoline to expand which, if overfilled, may leak through air vent screw when it is open. Leaking gasoline is a dangerous fire hazard.

ENOW00028-A

WARNING

Consult an authorized dealer for details on handling gasoline, if necessary.

Gasoline and its vapors are very flammable and can be explosive.

When carrying a fuel tank containing gasoline:

- Close the fuel tank cap and air vent screw of fuel tank cap, or gasoline vapor will be emitted through the air vent screw, creating a fire hazard.
- Do not smoke.

When or before refueling:

- Be sure to remove the static electricity charged in your body before refueling.
- The sparks due to static electricity may cause explosion of flammable gasoline.
- Stop the engine, and do not start the engine during refueling.
- Do not smoke.
- Be careful not to overfill fuel tank. Wipe up any spilled gasoline immediately.

When or before cleaning the gasoline tank:

- Dismount fuel tank from the boat.
- Place the fuel tank away from every source of ignition, such as sparks or open flames.
- Do the work outdoors or in a well ventilated area.
- Wipe off gasoline well immediately if spilled.
-

After cleaning gasoline tank:

- Wipe off gasoline well immediately if spilled.
- If the fuel tank is disassembled for cleaning, reassemble carefully. Imperfect assembly may cause a fuel leak, possibly leading to fire or explosion.
- Dispose aged or contaminated gasoline in accordance with local regulations.

ENOW00029-A

WARNING

When opening fuel tank cap, be sure to follow the procedure described below. Fuel could blast out through the fuel tank cap in case the cap is loosened by using another procedure when internal pressure of fuel tank is raised by heat from sources such as sun light.

1. Full open the air vent screw on the fuel tank cap and release internal pressure.

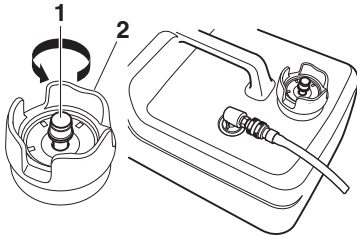

ENOF00417-0

1. Air vent screw
 2. Fuel tank cap
2. Open the fuel tank cap slowly.
 3. Fill the fuel carefully not to over flow.

6

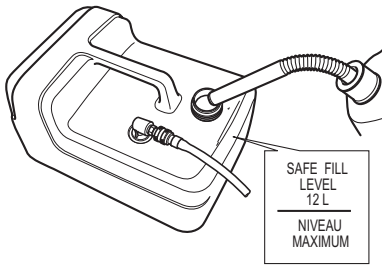

ENOF00419-A

4. After filling the tank, close the fuel tank cap.

ENOM1002-0

3. Engine oil recommendation

ENOW0002A-A

CAUTION

Use of engine oils that do not meet these requirements will result in reduced engine life, and other engine problems.

Use a genuine engine oil or recommended one (TCW3). Refer to your Distributor. Will not recommend use of other two stroke engine oil.

Add engine oil into fuel oil tank. The mixing ratio with gasoline is 50 : 1 (50 parts gasoline and one part oil). Mix well by hand. The mixing ratio during break-in running is 25 : 1.

Mixing Ratio

	Gasoline : Engine Oil
During break-in	25 : 1
After break-in	50 : 1

Fuel by Oil Mixing (50:1, 25:1)

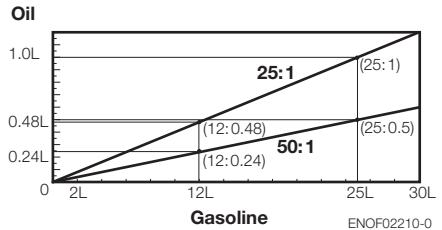

ENOF02210-0

ENOM1003-0

Engine oil – gasoline mixing procedure

ENOW00937-0

CAUTION

- Do not use other than two stroke engine oil with specified grade, or the engine may be damaged.
- Do not use fuel prepared in other than specified mixing ratio.
 - Lack of engine oil can cause severe engine trouble such as piston seizure.
 - Excess of engine oil can shorten spark plug life, and/or cause increase of noxious exhaust.

For quantities of engine oil and gasoline to be pre-mixed, refer to table in previous page.

■ **When portable fuel tank is used for operation of outboard motor(s):**

- 1 Pour engine oil into fuel tank, and then, gasoline.
- 2 Put cap on the tank, and close tightly.
- 3 Close air vent plug tightly.

ENOW00938-0

⚠ WARNING

Loose cap or air vent plug can cause leak of fuel during shaking the tank.

- 4 Shake the tank to mix engine oil and gasoline well and even.

■ **When fuel tank built in the boat is used for operation of outboard motor(s):**

- 1 Prepare separate fuel container for pre-mixing.

- 2 Pour engine oil into fuel container, and then, gasoline.
- 3 Put cap on the container, and close tightly.
- 4 Shake the container to mix engine oil and gasoline well and even.
- 5 Pour the mixture into fuel tank.

ENON00922-0-0

Notes

- It is recommended to pre-mix by using separate fuel container. Attempting to pre-mix in the fuel tank built-in the boat can make the mixture uneven.
- If built-in fuel tank is used for mixing, pour engine oil into the tank little by little while putting gasoline into the tank.

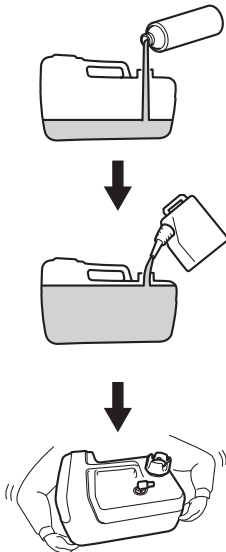

ENOF01709-A

JENOM00033-A

4. Break-In

Your new outboard motor and lower unit require break-in for the moving components according to the conditions described in the following time table.

Please refer to ENGINE OPERATION section (See page 29) to learn how to correctly start and operate the outboard motor.

ENOW00024-A

WARNING

Do not operate the outboard motor in closed area or area with no forced ventilation.

Exhaust gas emitted by this outboard motor contains carbon monoxide that will cause death if inhaled continuously. Inhaling the gas initially causes symptoms such as feeling of sickness, drowsiness and headache.

During operation of the outboard motor:

- **Keep peripheral area well ventilated.**
- **Always attempt to stay on the windward side of emission.**

ENOW00023-0

CAUTION

Operating the outboard motor without break-in can shorten service life of the product.

If any abnormality is experienced during the break-in:

- **Discontinue the operation immediately.**
- **Have the dealer check the product and take proper action(s) if necessary.**

ENOM01004-0

Fuel mixing ratio for break-in

Gasoline 25: Genuine Engine Oil 1

25:1 when using genuine engine oil or the recommended one (TCW3).

ENON00008-0

Note

Proper break-in allows outboard motor to deliver it full performance for longer service life.

6

	1-10 min	10 min - 2 hrs	2-3 hrs	3-10 hrs	After 10 hrs
Throttle Position	Idle	Less than 1/2 throttle	Less than 3/4 throttle	3/4 throttle	Full throttle available
Speed		Approx. 3000 rpm max	Full throttle run allowed for 1 min every 10 min	Approx. 4000 rpm. Full throttle run allowed for 2 min every 10 min	

ENGINE OPERATION

ENOM00042-0

Before starting

ENOW00022-B

CAUTION

Be sure to fill the engine before starting engine. (To properly fill the engine with oil follow the instructions. See page 26)

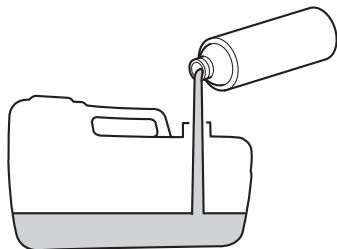

ENOF01710-A

ENOW00027-C

CAUTION

Before starting engine for the first time after reassembling engine or off-season storage, disconnect stop switch lock and crank approximately 10 times in order to circulate the engine oil.

ENOM00044-E

1. Fuel feeding

ENOW00029-A

WARNING

When opening fuel tank cap, be sure to follow the procedure described below. Fuel could blast out through the fuel tank cap in case the cap is loosened by using another procedure when internal pressure of fuel

tank is raised by heat from sources such as sun light.

1. Full open the air vent screw on the fuel tank cap.

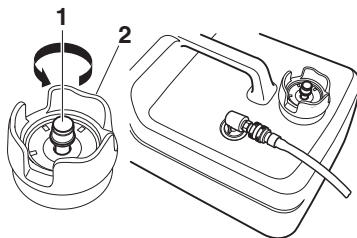

ENOF00417-0

1. Air vent screw
2. Fuel tank cap
2. Open the fuel tank cap slowly and release internal pressure completely. After that, close the fuel tank.
3. Connect the fuel connector to the engine and fuel tank.

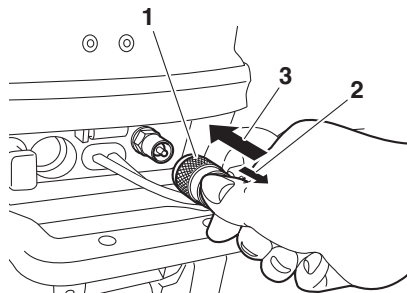

ENOF02211-0

1. Fuel connector
2. Pull
3. Insert

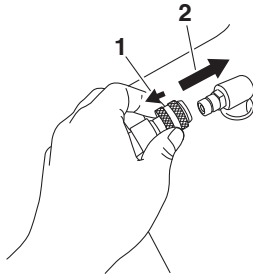

ENOF00861-A

1. Pull
2. Insert
4. Squeeze primer bulb until it becomes stiff to feed fuel to carburetor. Direct arrow mark upward when priming.



ENOF00862-0

1. Engine side
2. Fuel tank side

Do not squeeze primer bulb with engine running or when the outboard motor is tilted up. Otherwise, fuel could overflow.

ENOM00045-A

2. Starting the engine

ENOW00036-A

CAUTION

When the engine is started in the test tank, to avoid over heating and water pump damage, be sure the water level is at least 10 cm (4 in.) above the anti ventilation plate.

Run the engine only at idling.

And be sure to remove the propeller, when starting the engine in the test tank. (See page 54)

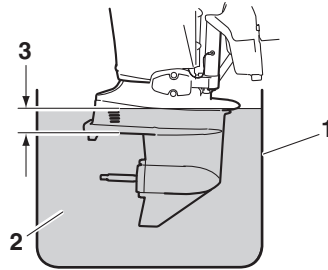

ENOF00863-0

1. Test tank
2. Water
3. Over 10 cm (4 in.)

ENOW00036-0

CAUTION

Be sure to stop engine immediately if cooling water check port is not discharging water, and check if cooling water intake is blocked. Operating engine could lead to overheating potentially leading to engine damage. Consult an authorized dealer if the cause cannot be found.

This model is provided with start in gear protection.

ENON00010-0

Note

Start-in-gear protection prevents engine from starting at other than neutral shift. In-gear starting of engine will move the boat immediately, potentially leading to falling down or causing passenger(s) to be thrown overboard.

ENOM01005-A

Tiller handle type

1. Be sure to install the stop switch lock to the stop switch, and attach the stop switch lanyard securely to the operator or to the operator's PFD (Personal Flotation Device.)

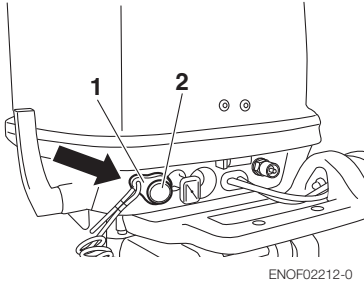

1. Stop switch lock
2. Stop switch

2. Set the control lever in the Neutral position.

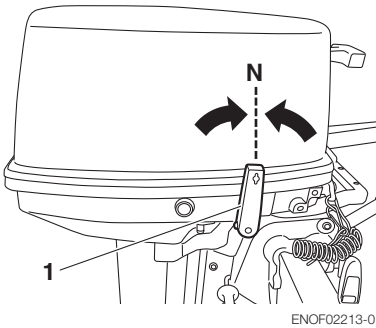

1. Shift lever

3. Set the throttle grip to START position.

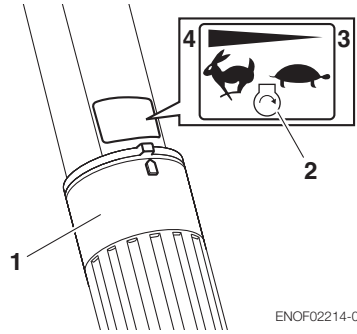

1. Throttle grip
2. START position
3. Fully closed
4. Fully opened

4. Pull the choke knob fully.

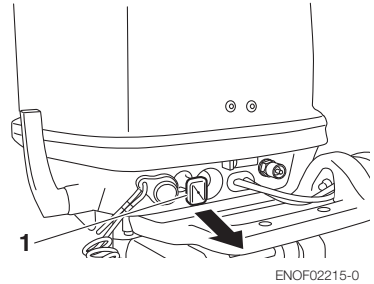

1. Choke knob

(For manual starter type)

5. Pull the starter handle slowly until you feel engagement, keep pulling till you feel less resistance. Then pull it quickly. repeat if necessary until started.

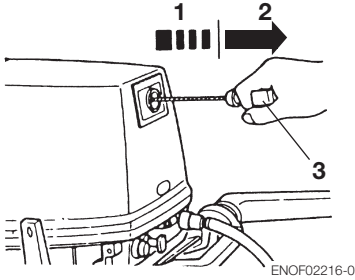

1. Slowly
2. Quickly
3. Starter handle

7 (For electrical starter type)

5. Push the starter switch button and release the button when the engine has started.

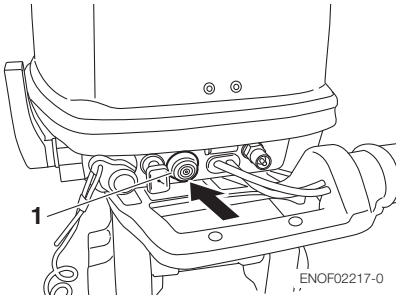

1. Starter switch button
- ENOW00032-0

CAUTION

Do not keep turning starter motor for over 5 seconds, or the battery may be consumed, potentially making the engine starting impossible and/or damaging the starter.

If cranking over 5 seconds fails to start engine, return main switch to “ON”, and crank engine again after 10 seconds or more.

6. Return the choke knob fully after engine has started.
7. Check the cooling water from cooling water check port.

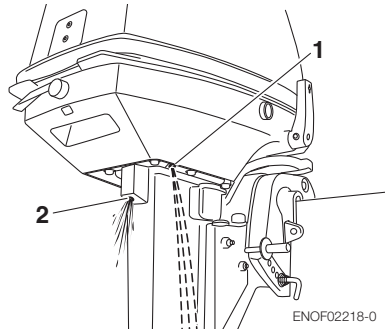

1. Cooling water check port
2. Idle port

ENOM00042-C
Emergency starting

ENOW00099-A

WARNING

When the emergency starter rope is used for starting engine;

- Start in gear protection does not work. Be sure to shift is at neutral position. Otherwise the engine will move the boat immediately and cause personal injury.
- Be careful that your clothes or other items do not get caught in the rotating engine parts.
- To prevent accident and injury by rotating parts, do not re-attach flywheel cover and the top cow! after the engine has been started.

- Do not pull starter rope if any bystander is behind. The action can injure the bystander.
- Attach engine stop switch lanyard to clothing or any part of body like arm before starting engine.

1. Remove the top cowl.

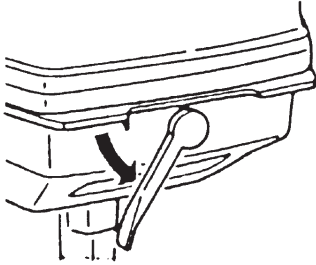

ENOF02219-0

2. Disconnect the rink of the starter lock rod.

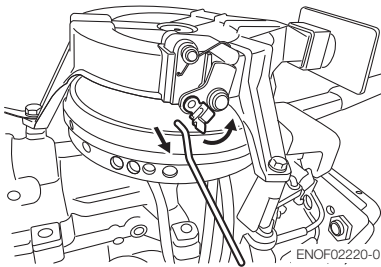

ENOF02220-0

3. Remove the bolts (3pcs) and remove the recoil starter.

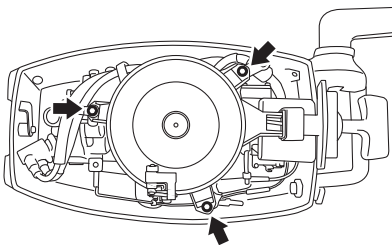

ENOF02221-0

4. Insert the knotted end of the starter rope into the notch in the flywheel and wind the rope around the flywheel several turns clockwise.

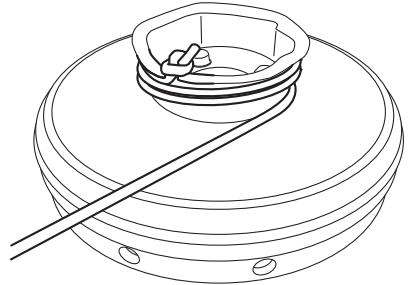

ENOF02222-0

5. Tie a loop in the another end of the emergency starter rope and attach socket wrench that is included in the tool kit.

ENOW00860-0

⚠ CAUTION

Be sure to keep the harness away from the rotation parts.

6. Be sure to install the stop switch lock to the stop switch, and attach the stop switch lanyard securely to the operator or to the operator's PFD (Personal Flo-tation Device.)
7. Set the control lever in the Neutral position.

- Pull the starter handle slowly until you feel engagement, keep pulling till you feel less resistance. Then pull it quickly.

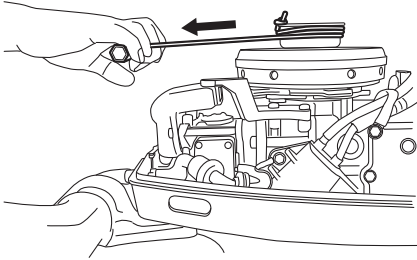

ENOF02223-0

- After engine starts, do not reinstall fly-wheel cover and top cowl.

ENOM00043-A

3. Warming up the engine

ENOW00932-0

CAUTION

Be sure to check that cooling water is coming out of the cooling water check port during warm up.

Warm the engine at low engine speeds for about

3 minutes : above 41°F (5 °C)

5 minutes at 2000 rpm : above 41°F (5 °C)

This allows the lubricating oil to circulate to all parts of the engine. Operating the engine without warm up shortens the engine's life.

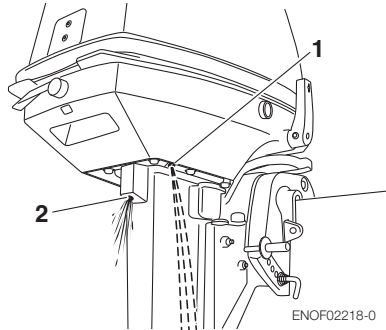

- Cooling water check port
- Idle port

ENOM00044-A

Engine speeds

Idling speed after warming up.

Trotling speed (in Forward)	Idling speed (in Neutral)
750 rpm	950 rpm

ENOM00046-A

4. Forward, reverse, and acceleration

ENOW00037-0

WARNING

Before shifting into forward or reverse, make sure that boat is properly moored and outboard motor can be steered fully to the right and left. Make sure that no swimmer(s) is ahead or astern of the boat.

ENOW00038-A

WARNING

- Attach other end of emergency stop switch lanyard to the operator's PFD (Personal Flotation device) or arm and keep it attached during cruising.
- Do not attach the tether to a part of clothing that can be torn easily when pulled.
- Arrange the tether so that will not be caught by any object when pulled.

- Be careful not to pull the tether accidentally during cruising. Unintentional stop of engine can cause loss of control of outboard motor. Rapid loss of engine power can lead to falling down or causing passenger(s) to be thrown overboard.

ENOW00042-0

 **WARNING**

- Do not shift into Reverse during planing, or control will be lost leading to serious personal injury, boat may swamp, and/or hull may be damaged.
- Do not shift into Reverse during cruising, or control may be lost, falling down or causing passenger(s) to be thrown overboard. Leading to serious personal injury, and steering system and/or shifting mechanism may be damaged.

ENOW00861-0

 **WARNING**

Do not shift at high boat speed, or control may be lost, falling down or causing passenger(s) to be thrown overboard. Leading to serious personal injury.

ENOW00862-0

 **CAUTION**

Gear and clutch damage may occur if shifting at high engine speed.
Engine must be in the slow idle position before shifting is attempted.

ENOW00863-0

 **CAUTION**

Idle speed may be higher during warming up of engine. If shifted to Forward or Reverse during warming up, it may be difficult to shift back to neutral. In such case,

stop engine, shift to neutral, and restart engine to warm up.

ENON00014-0

Note

Frequent shifting to forward or reverse can accelerate wear or degradation of parts. In such case, replace gear oil earlier than the period specified.

ENOW00864-0

 **CAUTION**

Do not increase engine speed unnecessarily when the shift is in neutral and reverse, or engine damage may occur.

ENOM00890-A

Tiller handle type

ENOW00865-A

 **CAUTION**

Do not force to shift when the throttle grip is not in the fully closed position, otherwise, steering system and/or shifting mechanism may be damaged.

ENOW00867-0

 **WARNING**

Sudden acceleration and deceleration may cause passenger(s) to be thrown overboard or falling down.

Forward

1. Turn the throttle grip to reduce engine speed.
2. When the engine reaches trolling (or idling) speed, quickly pull the shift lever to the Forward position.

Reverse

1. Turn the throttle grip to reduce engine speed.

- When the engine reaches trolling (or idling) speed, quickly pull the shift lever to the Reverse position.

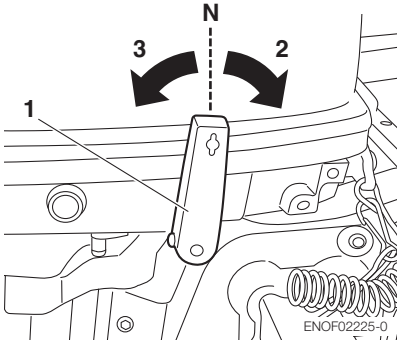

- Shift lever
- Forward
- Reverse

Acceleration

ENOW00867-0

WARNING

Sudden acceleration and deceleration may cause passenger(s) to be thrown overboard or falling down.

Open throttle grip gradually.

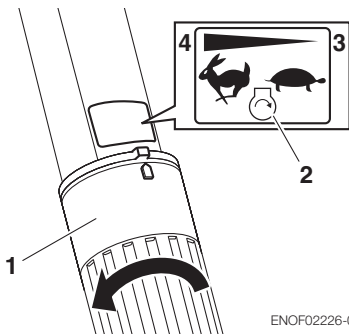

- Throttle grip
- START position
- Fully closed
- Fully opened

ENOM00049-A

5. Stopping the engine

ENOW00868-0

WARNING

Be careful not to remove engine stop switch lanyard from engine accidentally while boat is running. Sudden stop of engine can cause loss of steering control. It can also cause loss of boat speed, possibly leading the crew(s) and or objects on the boat to be thrown forward due to inertial force.

Tiller handle type

- Turn the throttle grip to the fully closed position.

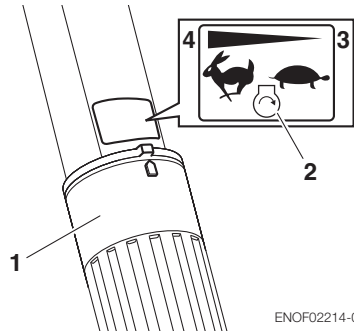

- Throttle grip
 - START position
 - Fully closed
 - Fully opened
- Put the shift lever in the Neutral position.
Run the engine for 2-3 minutes at idling speed for cooling down if it has been running at full speed.

- Push the stop switch for a few seconds to stop the engine.

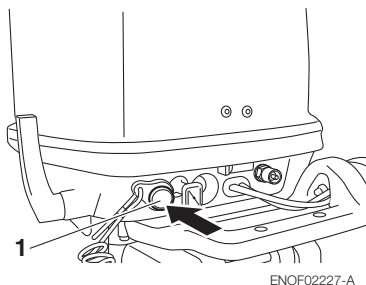

- Stop switch

ENOW00869-0

! WARNING

After stopping the engine:

- Close the air vent screw on the fuel tank cap.
- Disconnect the fuel connector of the engine and the fuel tank.
- Disconnect the battery cord, after each use.

Emergency engine stopping

Remove stop switch lock to stop the engine.

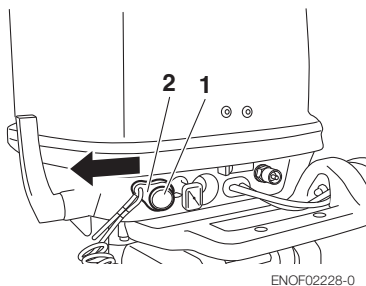

- Stop switch
- Stop switch lock

ENOF02228-0

ENOM00920-0

6. Steering

ENOW00870-0

! WARNING

Sudden steering may cause passenger(s) to be thrown overboard or falling down.

Tiller handle type

Right turn

Move the tiller handle to the left

Left turn

Move the tiller handle to the right.

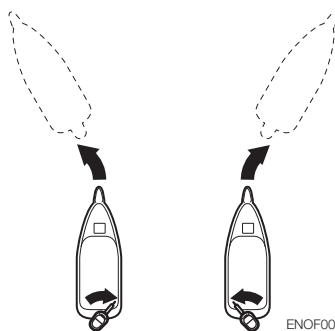

ENOF00892-0

ENOM00050-0

7. Trim angle

ENOW00043-A

! WARNING

- Adjust the trim angle when the engine is stopped.
- Do not put hand or finger in between outboard motor body and clamp bracket when adjusting trim angle to prevent injury in case the outboard motor body falls.
- Unsuitable trim position can cause loss of control of boat. When testing a trim position, run boat slow initially to see if it can be controlled safely.

ENOW00044-0

! WARNING

Excessive trim up or down may lead to unstable boat operation, potentially causing the steering difficulty that leads to accident during cruising.

- Do not cruise at high speed if improper trim position is suspected. Stop the boat and readjust trim angle before continuing cruise.
- For outboard motor model with PTT switch on the bottom cowl, do not operate the switch during cruising, or control of boat may be lost.

The trim angle of the outboard motor can be adjusted to suit the transom angle of the hull, and load conditions. Choose an appropriate trim angle that will allow the anti-ventilation plate to run parallel to the water surface during operation.

7

ENOM00052-0

Proper trim angle

The position of the thrust rod is correct if the hull is horizontal during operation.

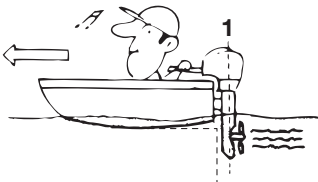

ENOF00051-1

1. Perpendicular to the water surface

ENOM00053-0

Improper trim angle (bow rises too high)

Set the thrust rod lower if the bow of the boat rises above horizontal.



ENOF00052-0

ENOM00054-0

Improper trim angle (bow dips into the water)

Set the thrust rod higher if the bow of the boat is below horizontal.



ENOF00053-0

■ Manual Tilt type

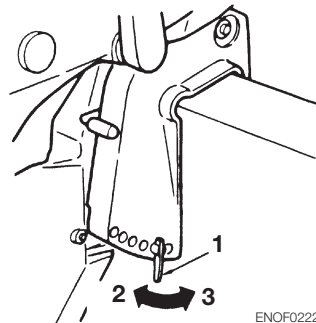

ENOF02229-0

1. Thrust rod
2. Higher
3. Lower

Trim angle adjustment (Manual tilt type)

The transom angle adjustment

1. Stop the engine.
2. Shift into neutral.
3. Raise the outboard motor to the tilt up position.
4. Change the thrust rod position as following picture.

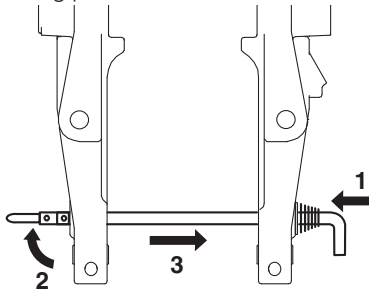

ENOF01238-1

1. Push in
2. Rise the stopper
3. Pull out
5. Reinstall the thrust rod securely.
6. Gently lower the outboard.

ENOM00060-A

8. Tilt up and down

ENOW00055-0

! WARNING

Do not tilt up or down outboard motor when swimmer(s) or passenger is near to prevent them from being caught between outboard motor body and clamp bracket in case the outboard motor body falls.

ENOW00048-0

! WARNING

When tilting up or down, be careful not to place your hand between the swivel bracket and the stern bracket.

Be sure to tilt the outboard motor down slowly.

ENOW00056-A

! WARNING

When tilting up outboard motor with fuel joint for over a few minutes, be sure to disconnect fuel hose, or fuel may leak, potentially catching fire.

ENOW00057-0

! CAUTION

Do not tilt up outboard motor while engine operates, or no cooling water may be fed, leading to engine seizure due to overheating.

ENON00921-0

Note

Before tilting the outboard motor up, after stopping the motor leave it in the running position for about a minute to allow water to drain from inside the engine.

Tilt up

With the shift lever in Neutral or Forward, fully tilt the motor up toward you by holding the tilt handle provide at the rear of the top cowl. Then slightly lower the motor for locking in the up position.

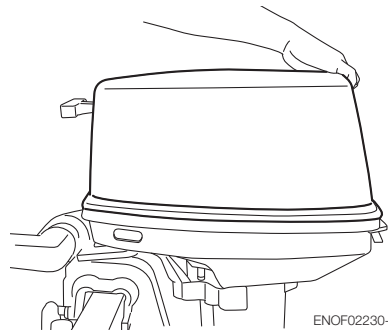

ENOF02230-0

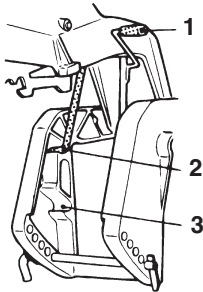

ENOF00544-A

1. Tilt lever
2. Tilt up position
3. Shallow water operation lever

ENOM00063-A

Tilt down

Slightly tilt the motor up, and pull the tilt lever toward you to release the tilt-lock. Then lower the motor slowly.

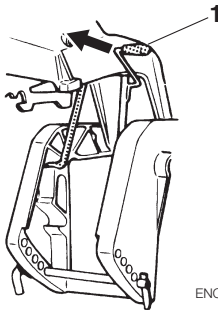

ENOF00545-A

1. Tilt lever

ENOM00068-A

9. Shallow water operation

ENOW00051-0

! WARNING

During shallow water operation, be careful not to place your hand between the swivel bracket and the clamp bracket. Be sure to tilt the outboard motor down slowly.

ENOW00053-0

! CAUTION

While in shallow water drive position, do not operate the outboard motor in Reverse. Operate the outboard motor at slow speed and keep the cooling water intake submerged.

ENOW00054-A

! CAUTION

Do not overtilt outboard motor when driving shallow water, or air may be sucked through water inlet, potentially leading to engine overheating.

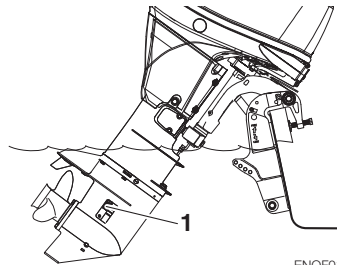

ENOF01144-A

1. Water inlet

Shallow water running position:

1. With the shift lever in Neutral or Forward, tilt the motor up slowly by about 40° and then lower the tilt lever for setting at the shallow water running position.

Return to normal running position:

2. Tilt the motor up fully and then return the motor down slowly to the normal running position.

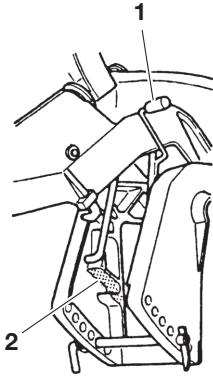

ENOF00549-A

1. Tilt lever
2. Shallow water running position

REMOVING AND CARRYING THE OUTBOARD MOTOR

ENOM00070-B

1. Removing the outboard motor

ENOW00064-0

⚠ CAUTION

Engine may be hot immediately after operating and could cause burns if touched. Allow engine to cool down before attempting to carry the outboard.

1. Stop the engine.
2. Remove the top cowl.
3. Disconnect the fuel connector, the remote control cables and the battery cords from the outboard motor.
4. Remove the outboard motor from boat and completely drain the water from the gear case.

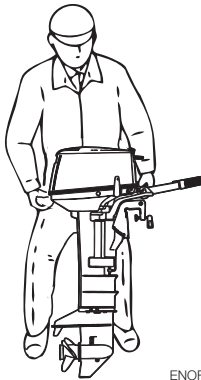

ENOF02208-0

ENOM00071-A

2. Carrying the outboard motor

ENOW00933-0

⚠ WARNING

Be sure to disconnect fuel connector except when operating engine.

Fuel leakage is a fire or explosion hazard, which can cause serious injury or death.

ENOW00065-0

⚠ WARNING

Close air vent screw of fuel tank before carrying or storing outboard motor and fuel tank, or fuel may leak, potentially catching fire.

ENOW00066-0

⚠ CAUTION

- Do not give a shock to an outboard motor during transportation. It becomes a cause of breakage.
- Do not carry or store outboard motor in any of positions described below. Otherwise, engine damage or property damage could result from leaking oil.

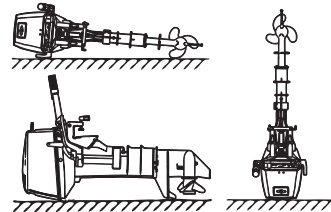

ENOF02231-0

Keep the outboard motor in a vertical position when carrying.

The optional outboard motor stand is recommended for keeping the outboard motor vertical both during transport and storage.

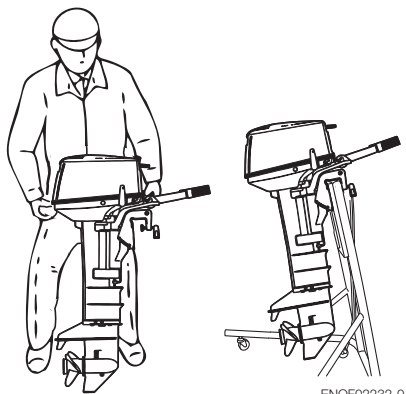

ENOF02232-0

ENON00021-A
Note

- If the outboard motor must be laid down be sure drain the fuel and engine oil, then the port side faces down as shown in the drawing above.
- Elevate power unit 2 inches to 4 inches if traveling to avoid oil spillage.

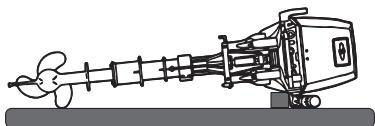

ENOF02233-0

ENOM00072-A

3. Trailing

ENOW00072-0

CAUTION

Trailing in the tilted position may cause damage to the outboard motor, boat, etc.

ENOW00073-A

WARNING

Be sure to disconnect fuel connector except when operating engine. Fuel leakage is a fire or explosion hazard, which can cause serious injury or death.

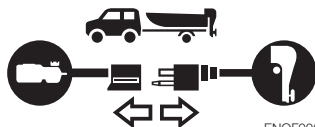

ENOF00075-1

ENOW00068-0

WARNING

Close air vent screw of fuel tank and fuel cock before carrying or storing outboard motor and fuel tank, or fuel may leak, potentially catching fire.

ENOW00071-0

CAUTION

The tilt support device supplied on your outboard motor is not intended for towing. It is intended to support the outboard motor while the boat is docked, beached, etc.

When transporting a boat on a trailer with the outboard motor still attached, disconnect the fuel line from the outboard motor beforehand and keep the outboard motor in the normal running position or on a transom saver bar.

Tiller handle type

To prevent the outboard motor from moving when it is attached on a boat during transport on a trailer, properly tighten the steering friction bolt (page 44).

ADJUSTMENT

ENOM00073-B

1. Steering friction

ENOW00074-A

⚠ WARNING

Do not overtighten the steering friction lever it could result in difficulty of movement resulting in the loss of control causing an accident and could lead to severe injury.

Adjust this lever to achieve the desired steering friction (drag) on the tiller handle. Move lever towards (2) to tighten friction and move lever towards (3) to loosen friction.

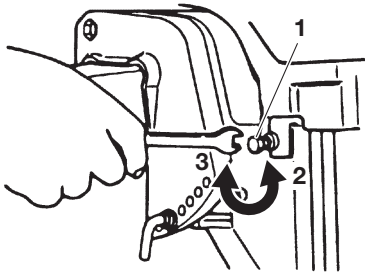

ENOF02234-0

1. Steering friction bolt
2. Lighter
3. Heavier

ENOM00074-A

2. Throttle grip friction

ENOW00074-B

⚠ WARNING

Do not overtighten the throttle adjustment screw or it could result in difficulty of movement resulting in the loss of control causing an accident and could lead to severe injury.

Friction adjustment of the throttle grip can

be made with the throttle adjustment screw.

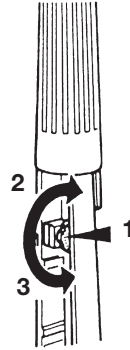

ENOF02235-0

1. Throttle friction adjustment screw
2. Heavier
3. Lighter

ENOM00076-0

3. Trim tab adjustment

ENOW00076-0

⚠ WARNING

- Be sure that outboard motor is secured to transom or service stand, or accidental drop or fall of outboard motor could lead to severe personal injury.
- Be sure to lock outboard motor if it is tilted up, or accidental fall of outboard motor could lead to severe personal injury.
- Do not go under outboard motor tilted up and locked, or accidental fall of outboard motor could lead to severe personal injury.

ENOW00075-0

⚠ WARNING

Inappropriate adjustment of trim tab could cause steering difficulty. After installing or

readjusting trim tab, check if steering function is even.

If straight-line cruising can not be achieved, adjust the trim tab located under the anti-ventilation plate.

- If the boat veers toward the left direct the trim tab towards A (left from rear of boat).
- If the boat veers toward the right direct the trim tab towards B (right from rear of boat).

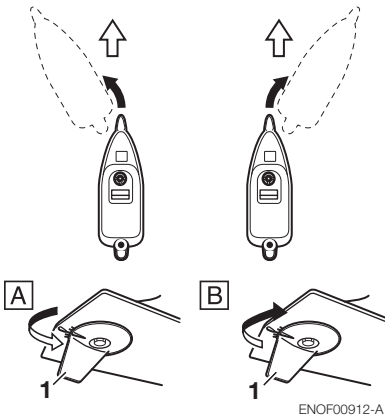

ENOF00912-A

1. Trim tab

ENON00022-A

Notes

- After adjustment securely tighten the trim tab fixing bolt.
 - Check for looseness of the bolt and the trim tab at regular intervals.
-

INSPECTION AND MAINTENANCE

ENOM00077-0

Care of your outboard motor

To keep your outboard motor in the best operating condition, it is very important that you perform daily and periodic maintenance as suggested in the maintenance schedules that follow.

ENOW00077-0



CAUTION

- **Your personal safety and that of your passengers depends on how well you maintain your outboard motor. Carefully observe all of the inspection and maintenance procedures described in this section.**
 - **The maintenance intervals shown in the checklist apply to an outboard motor in normal use. If you use your outboard motor under severe conditions such as frequent full-throttle operation, frequent operation in brackish water, or for commercial use, maintenance should be performed at shorter intervals. If in doubt, consult your dealer for advice.**
 - **We strongly recommend that you use only genuine replacement parts on your outboard motor. Damage to your outboard motor arising from the use of other than genuine parts is not covered under the warranty.**
-

ENOM01203-0

1. Daily Inspection

Perform the following checks before and after use.

ENOW00078-0

 **WARNING**

Do not use outboard motor if any abnormality is found during pre-operation check or it could result in severe damage to the motor or severe personal injury.

Item	Points to Check	Action
Fuel System	<ul style="list-style-type: none"> • Check the amount of fuel in the tank. • Check for debris or water in the fuel filters. • Check the rubber hoses for fuel leakage. 	Replenish Clean Replace *1
Electrical Equipment	<ul style="list-style-type: none"> • Check that the main switch functions normally. • Check that the battery electrolyte level and specific gravity are normal. • Check for loose connections on the battery terminal. • Check that the stop switch functions normally and make sure the lock plate is there. • Check cords for loose connections and damage. • Check the spark plugs for dirt, wear and carbon build-up. 	Replace *1 Replenish or recharge Retighten Remedy or replace *1 Correct or replace *1 Clean or replace *1
Choke and Throttle System	<ul style="list-style-type: none"> • Check that the choke solenoid and valve for the carburetor function normally. • Check if the carburetor and magneto work normally when turning the throttle grip, and check links for looseness. 	Replace *1 Correct *1
Recoil Starter	<ul style="list-style-type: none"> • Check the rope for wear and chafing. • Check the ratchet engagement. 	Replace *1 Correct or replace *1
Clutch and Propeller System	<ul style="list-style-type: none"> • Check that clutch engages correctly when operating the shift lever and remote control. • Visually Check propeller for bent or damaged blades. • Check the propeller nut is tightened and the split pin is present. 	Adjust *1 Replace
Installation of Motor	<ul style="list-style-type: none"> • Check all the bolts attaching the motor to the boat. • Check the thrust rod installation. 	Tighten Tighten
Cooling Water	<ul style="list-style-type: none"> • Check that cooling water is discharged from the cooling water check port after the engine has started. 	Repair *1
Tools and Spares	<ul style="list-style-type: none"> • Check that there are tools and spare parts for replacing spark plugs, the propeller, etc. • Check that you have the spare rope. 	
Steering Devices	<ul style="list-style-type: none"> • Check the operation of the steering handle and remote control. 	Repair *1
Other Parts	<ul style="list-style-type: none"> • Check if the anode and trim tab are securely installed. • Check the anode and trim tab for corrosion and deformation. 	Repair or Replace Replace

*1 Have this handled by your dealer.

ENOM00083-0

Washing outboard motor

ENOW00081-0

⚠ WARNING

Do not start engine without removing propeller, or accidentally turning propeller could cause personal injury.

ENOW00082-0

⚠ WARNING

Never start or operate the engine indoors or in any space which is not well ventilated. Exhaust gas contains carbon monoxide, a colorless and odorless gas which can be fatal if inhaled for any length of time.

ENOW00920-0

⚠ CAUTION

When washing the outboard motor, be careful not to spray the water inside of the top cowl, especially electrical components.

ENON00026-0

Note

It is recommended to check chemical properties of water on which your outboard motor is regularly used.

10

If outboard motor is used in salt water, brackish water or water with a high acidic level, use fresh water to remove salt, chemicals or mud from exterior and cooling water passage after every cruising or before storing outboard motor for long time. Before flushing, remove the propeller and the forward thrust holder.

ENOM00085-D

Flushing attachment

ENOW00921-0

⚠ CAUTION

Do not operate the engine when flushing the outboard motor with a flushing attach-

ment as this can cause damage to the outboard motor.

ENOW00922-0

⚠ CAUTION

To prevent the engine from starting when you are near the propeller, remove the stop switch lock.

1. Tilt down the outboard motor.
2. Remove the water plug from the gear case, and screw in the flushing attachment.
3. Connect a water hose. Turn on the water and adjust the flow (Be sure to seal the water inlet, located in the gear case with tape).
4. Put the shift lever in the neutral position and start the engine. Continue flushing the outboard motor for 3 to 5 minutes at idling.
5. Stop the engine and water supply. Remove the flushing attachment and tape. After the flushing, be sure to reattach the water plug.

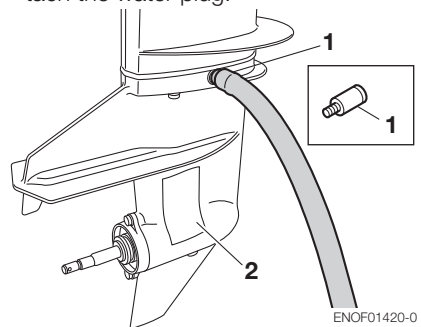

1. Flushing attachment (Option)
2. Water inlet

ENOM00085-A

Flushing by test tank

ENOW00081-0

⚠ WARNING

Do not start engine without removing propeller, or accidentally turning propeller could cause personal injury.

ENOW00082-0

⚠ WARNING

Never start or operate the engine indoors or in any space which is not well ventilated. Exhaust gas contains carbon monoxide, a colorless and odorless gas which can be fatal if inhaled for any length of time.

ENOW00036-A

⚠ CAUTION

When the engine is started in the test tank, to avoid over heating and water pump damage, be sure the water level is at least 10 cm (4 in.) above the anti ventilation plate.

And be sure to remove the propeller, when starting the engine in the test tank. (See page 54)

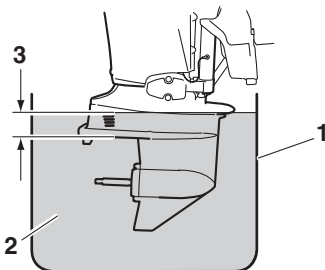

ENOF00863-0

1. Test tank
2. Water
3. Over 10 cm (4 in.)

ENOM00950-0

Fuse replacement (For electrical starter type)

ENOW00923-0

⚠ CAUTION

Before replacing a fuse, disconnect the battery cable from the battery negative (-) terminal. Failure to do so may cause a short-circuit.

ENOW00924-0

⚠ CAUTION

Never use a fuse with a rating that exceeds the specified rating as this could cause serious damage to the electrical system.

If a blown fuse is detected, try to determine the cause for this and correct it. If the cause for the problem is not corrected, the fuse will likely blow again.

If the fuse continues to blow, request an authorized Tohatsu dealer to inspect the outboard motor.

1. Stop the engine and disconnect the battery cable from the battery negative (-) terminal.
2. Remove the engine cover.
3. Remove the fuse box lid.

4. Remove the fuse and check it. If the fuse is blown, replace it with a fuse of the same specified rating.

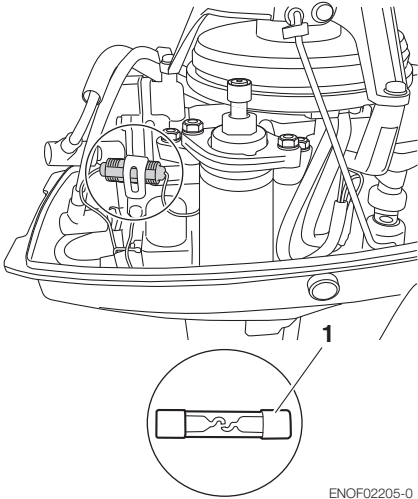

ENOF02205-0

1. Blown fuse

ENOM01503-0

2. Periodic Inspection

It is important to inspect and maintain your outboard motor regularly. At each interval on the chart below, be sure to perform the indicated servicing.

Maintenance intervals should be determined according to the number of hours or number of months, whichever comes first.

Item		Servicing Interval			Action	Remarks
		10 hours or 1 month	50 hours or 3 months	Every 100 hours or 6 months		
Fuel System	Carburetor *1			●	Strip, clean and adjust. Adjust idling.	
	Fuel filter	●	●	●	Check and clean or Replace if necessary.	
	Piping	●	●	●	Check and Replace if necessary.	
	Fuel tank	●		●	Clean.	
Ignition	Spark plugs	●		●	Check gaps. Remove carbon deposits or Replace if necessary.	0.9-1.0 mm (0.035-0.039 in)
	Ignition timing *1	●		●	Adjust timing.	
Starting System	Starter motor *1			●	Check for salt deposits and battery cable condition.	
	Battery	●	●	●	Check Installation, fluid quantity, gravity.	
	Starter rope	●	●	●	Check for wear or damage.	
Lower Unit	Propeller	●	●	●	Check for bend blades, damage, wear.	
	Gear oil	●	●	●	Change or replenish-oil and check for water leaks.	
	Water pump *1		●	●	Check for wear or damage.	Replace impeller every 12 months.
Bolt and Nuts		●	●	●	Retighten.	
Sliding and Rotating Parts. Grease Nipples			●	●	Apply and pump in grease.	
Outer Equipment		●	●	●	Check for corrosion.	
Anode			●	●	Check for corrosion and deformation.	Replace.

*1: Have this handled by your dealer.

ENON00030-0

Note

Your outboard motor should receive careful, and complete inspection at 300 hours. This is the best time for major maintenance procedures to be carried out.

ENOM00093-A

Fuel filters and fuel tank cleaning

ENOW00093-B

WARNING

Gasoline and its vapors are very flammable and can be explosive.

Keep out of reach of children.

- Avoid repeated or prolonged contact with skin or breathing of vapor.
- Do not start this procedure while engine is operating or hot even after stopping it.
- Place fuel filter away from every source of ignition such as sparks or open flames.
- Wipe off gasoline well immediately if spilled and dispose of it in accordance with local fire prevention and environment protection regulations.
- Install fuel filter with all related parts in place, or fuel leak could occur, leading to catching fire or explosion.
- Check fuel system regularly for leakage.
- Contact authorized dealer for fuel system services. Services by unqualified person could lead to engine damage.

Water or dirt in the fuel filter and tank will cause engine performance problems.

Check and clean the fuel filter and tank at specified times or after the outboard motor has been stored for a long period of time (over three months).

Fuel filters are provided inside the fuel tank and engine.

ENOM01504-0

Fuel filter (for engine)

1. Replace the fuel filter provided inside of engine cover if there is water or dirt inside.

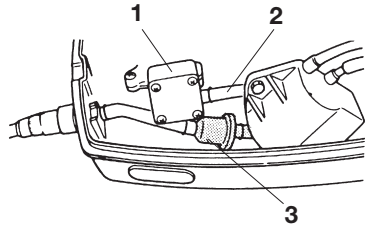

ENOF02236-0

1. Fuel pump
2. Fuel pipe
3. Fuel filter

ENOM00096-A

Fuel filter (for fuel tank)

1. Remove the fuel pickup elbow of the fuel tank by turning it counterclockwise.
2. Clean the fuel filter and check the O-ring. Replace it if necessary.
3. Reassemble all parts.

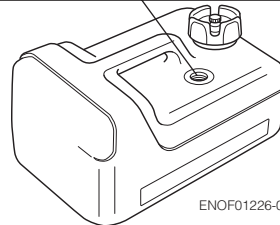
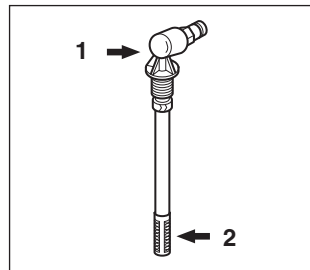

ENOF01226-0

1. Fuel pickup
2. Filter

ENOM00098-A

Gear oil replacement

ENOW00094-0

WARNING

- **Be sure that outboard motor is secured to transom or service stand, or accidental drop or fall of outboard motor could lead to severe personal injury.**
- **Be sure to lock outboard motor if it is tilted up, or accidental fall of outboard motor could lead to severe personal injury.**
- **Do not go under outboard motor tilted up and locked, or accidental fall of outboard motor could lead to severe personal injury.**

ENON00934-0

Note

Please dispose of used oil in a manner that is compatible with the environment. We suggest you take it in a sealed container to your local service station for reclamation. Do not throw it in the trash, pour it on the ground or down a drain.

1. Tilt down the outboard motor.
2. Remove the oil plugs (lower and upper), and completely drain the gear oil into a pan.

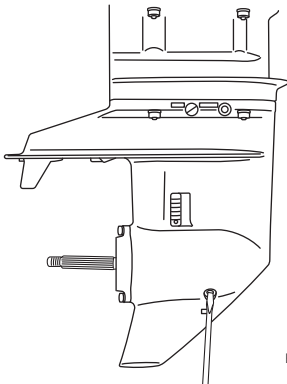

ENOF01424-0

3. Insert the oil tube nozzle into the lower oil plug hole, and fill with gear oil by squeezing the oil tube until oil flows out of the upper plug hole and bubbles have disappeared to remove the air.

ENON00033-0

Note

Use genuine gear oil or the recommended one (API GL-5: SAE #80 to #90). Required volume: approx. 320 mL (10.8 fl.Oz).

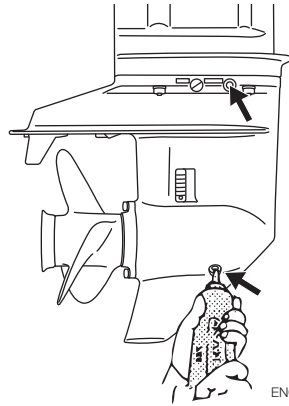

ENOF01430-0

4. Install the upper oil plug, and then remove oil tube nozzle and install the lower oil plug.

ENOW00095-0

CAUTION

Do not reuse oil plug gasket. Always use new gasket and tighten oil plug properly to prevent entry of water into lower unit.

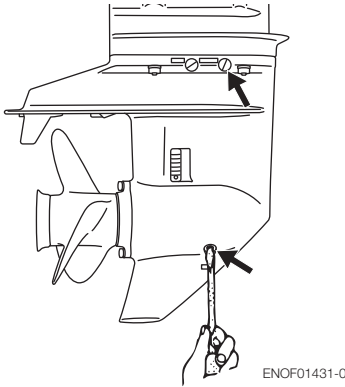

ENOW00928-0

CAUTION

Wipe off gear oil well immediately if spilled and dispose of it in accordance with local fire prevention and environment protection regulations.

ENON00032-0

Note

If water in the oil, giving it a milky colored appearance. Contact your dealer.

ENON00033-0

Note

Use genuine gear oil or the recommended one (API GL-5: SAE #80 to #90). Required volume: approx. 320 mL (10.8 fl.Oz).

10

ENOM00086-A

Propeller replacement

ENOW00084-0

WARNING

Do not begin propeller removal and installation procedure with spark plug caps attached, shift in forward or reverse, main switch at other than "OFF", engine stop switch lock attached to the switch, and starter key attached, or engine could accidentally start lead-

ing to serious personal injury. Disconnect battery cable if possible.

- The propeller edge is thin and sharp. Wear the grooves during replacement to protect your hands.

ENOW00086-0

CAUTION

- Do not install propeller without thrust holder, or propeller boss could be damaged.
- Do not reuse split pin.
- After installing split pin, spread the pin apart to prevent it from falling out which could lead to the propeller coming off during operation.

A worn-out or bent propeller will lower the motor's performance, and cause engine trouble.

- Put a piece of wood block between propeller blade and anti-ventilation plate to hold propeller.

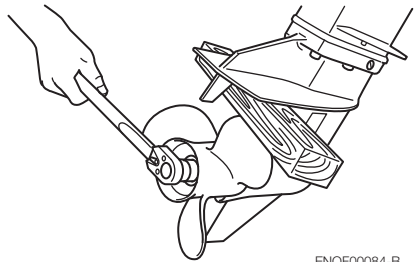

ENOF00084-B

- Remove the split pin, propeller nut and washer.
- Remove the propeller and thrust holder.
- Apply water proof grease to the propeller shaft before installing a new propeller.

5. Install the thrust holder, propeller, stopper, washer and propeller nut onto the shaft.

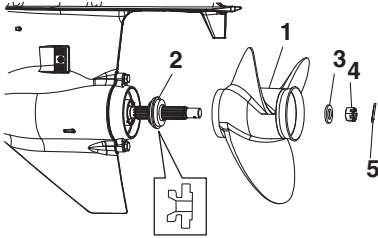

ENOF01432-0

1. Propeller
2. Thrust holder
3. Washer
4. Propeller nut
5. Split pin

6. Tighten the propeller nut to specified torque, and align one of grooves to propeller shaft hole.

Propeller nut torque:

12 Nm (9 ft-lb, 1.2kgf-m)

7. Install a new split pin into the nut hole and bend it.



ENOF00084-D

ENOM00087-A

Spark plugs replacement

ENOW00087-0

! WARNING

- Do not reuse spark plug with damaged insulation, or sparks can leak through crack, potentially leading to electric shock, explosion and/or fire.

- Do not touch spark plugs immediately after stopping engine as they will be hot and could cause severe burns if touched. Allow motor to cool down first.

ENOW00929-0

! CAUTION

Use only the recommended spark plugs. Spark plugs which have an different heat range may cause engine damage.

If the spark plug(s) is fouled, has carbon build up, or is worn, it should be replaced. When reusing spark plugs, remove dirt from the electrodes and adjust spark gap to specification.

1. Stop the engine.
2. Remove the top cowl.
3. Remove the spark plug caps.
4. Remove the spark plugs by turning it counter-clockwise, using a 21 mm (13/16 in) socket wrench and handle that is provided in tool bag.
5. Inspect the spark plug. Replace the spark plug if the electrodes are worn or if the insulators are cracked or chipped.
6. Measure the spark plug electrode gap with a wire type feeler gauge. The gap should be 0.9-1.0 mm (0.035-0.039 inches). If the gap is different, replace the spark plug with a new one
Use spark plug NGK BPR7HS-10

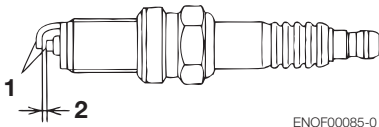

- 1. Electrode
- 2. Spark gap (0.9–1.0 mm, 0.035–0.039 in)

- 7. Install the spark plug by hand and turn it carefully to avoid cross-threading.
- 8. Tighten the spark plug to the specified torque.

ENON00028-0

Note

- **Spark plug torque:
25.0 Nm (18 ft-lb) [2.5 kgf-m]**

If a torque-wrench is not available when you are fitting a spark plug, a good estimate of the correct torque is 1/4 to 1/2 a turn past finger-tight. Have the spark plug adjusted to the correct torque as soon as possible with a torque-wrench.

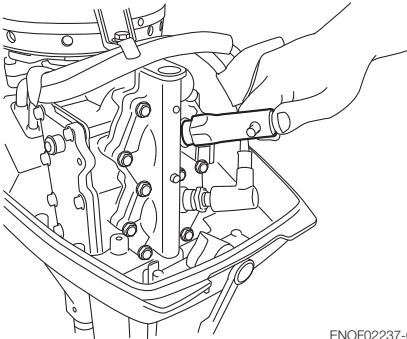

ENOM00088-A

Anode replacement

A sacrificial anode protects the outboard motor from electrolytic corrosion. Anode is located on the gear case, cylinder etc.. When the anode is eroded more than 1/3 of original size, replace it.

ENON00029-0

Notes

- Never grease or paint the anode.
- At each inspection re-tighten the anode attaching bolt. As it is likely to be subjected to electrolytic corrosion.

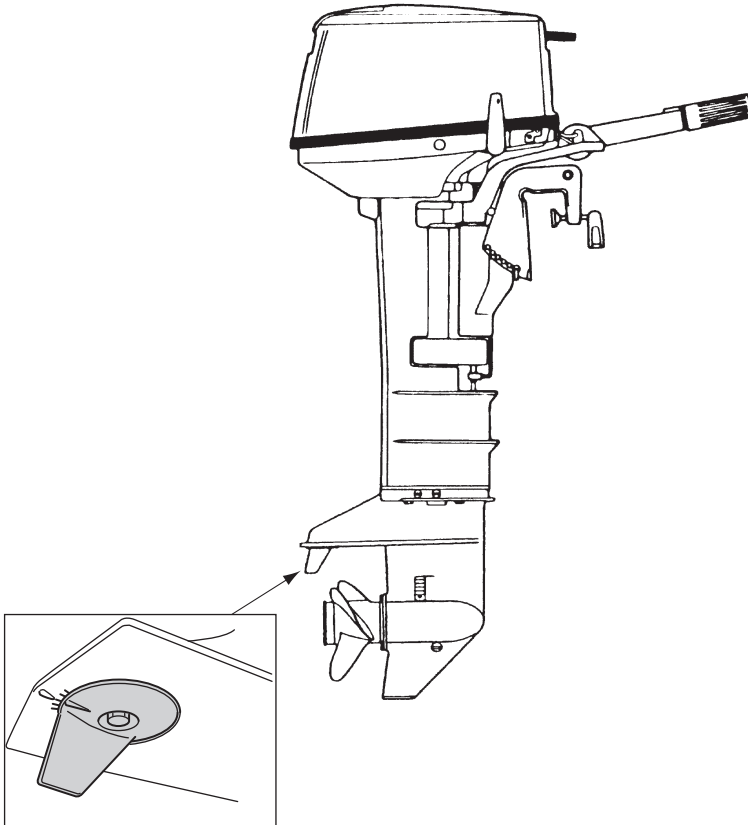

ENOM00960-0

Grease point

Apply water proof grease to the parts shown below.

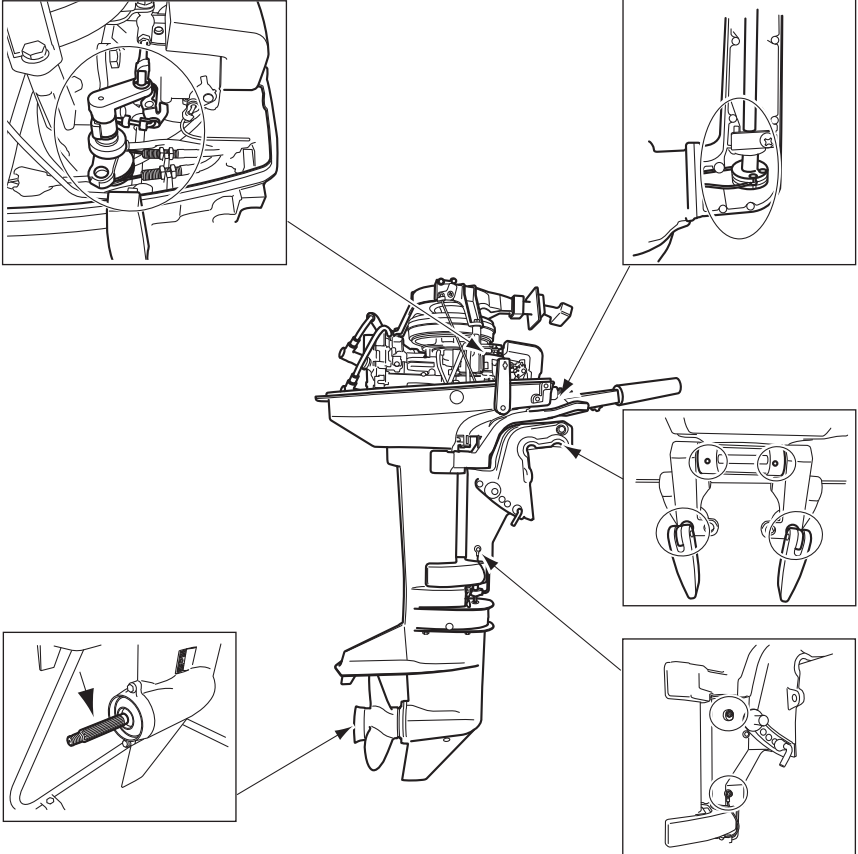

10

ENOM00100-A

3. Off-season storage

ENOW00934-0

! WARNING

- Be sure to disconnect fuel connector except when operating engine.
- Fuel leakage is a fire or explosion hazard, which can cause serious injury or death.

ENOW00097-0

! WARNING

Be sure to use cloth to remove fuel remaining in the cowl and dispose of it in accordance with local fire prevention and environment protection regulations.

ENOW00096-0

! CAUTION

Before servicing the motor for storage:

- Remove the battery cables.
- Remove the spark plug caps from the spark plugs.
- Do not run the motor out of the water.

Before you put your outboard motor in storage, it is a good opportunity to have it serviced and prepared by your dealer.

Be sure to use fuel stabilizer while running the motor before storage. (See page 60)

ENOM00101-C

Engine

1. Wash the engine exterior and flush the cooling water system thoroughly with fresh water. Drain the water completely.
Wipe off any surface water with an oily rag.
2. Remove the fuel hose from the outboard motor.

3. Drain all fuel from the fuel hoses, fuel pump, fuel filter (See page 52) and carburetor (See page 60), and clean these parts.

Keep in mind that if gasoline is kept in the carburetor for a long time, gum and varnish will develop, causing the float valve to stick, restricting the fuel flow.

4. Remove the spark plugs and put a teaspoon of engine oil or spray storage oil into the combustion chamber through the spark plug holes.
5. Pull the recoil starter several times to lubricate inside the cylinder.

ENOW00930-0

! WARNING

- Be sure to remove stop switch lock to prevent ignited the spark plugs.
- Put a cloth to spark plug hole and wipe up any spilled engine oil, when cranking the outboard motor.

6. Change the gear oil in the gear case (See page 53).
7. Apply grease to grease point (See page 58).
8. Stand the outboard motor up vertically in a dry place.

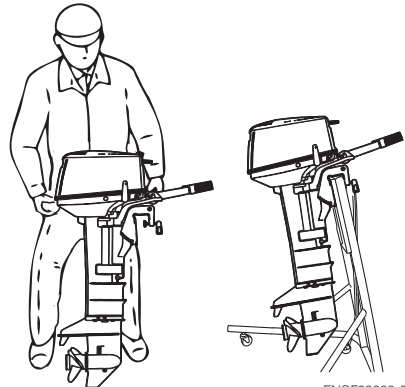

ENOF02232-0

ENOW0066-0

CAUTION

Do not carry or store outboard motor in any of positions described below. Otherwise, engine damage or property damage could result from leaking oil.

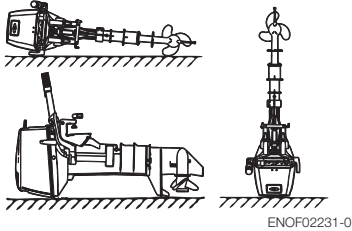

ENOF02231-0

ENON0021-A

Note

- If the outboard motor must be laid down be sure drain the fuel and engine oil, then the outboard motor on a cushion as shown in the drawing below (See page 43 and 60).
- Elevate power unit 2 inches to 4 inches if traveling to avoid oil spillage.

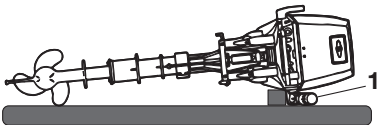

ENOF02233-A

1. Handle

ENOM00950-A

Adding a fuel stabilizer

When adding a fuel stabilizer additive (commercially available), first fill the fuel tank with fresh oil and fuel. If the fuel tank is only partially filled, air in the tank can cause the fuel to deteriorate during storage.

1. Before adding fuel stabilizer additive, drain the carburetor (See page 60).
2. Follow the instructions on the label when adding the fuel stabilizer additive.
3. After adding the additive, let the outboard motor run in the water for 10 minutes to make sure any old fuel in the fuel system has been completely replaced by the fuel with additive.
4. Turn the engine OFF

ENON00891-0

Note

If your motor is used occasionally, it is recommended to use a good fuel stabilizer in every tank of fuel and keep the container full to reduce condensation and evaporation.

ENOM00970-B

Fuel system draining

ENOW00028-A

WARNING

For details on handling fuel, contact an authorized dealer.

Fuel and fuel vapors are extremely flammable and can be explosive.

- If fuel is spilled, wipe it up immediately.
- Keep the fuel tank well away from sources of ignition, e.g. sparks or open flames
- Perform all work outdoors or in a well ventilated place.

ENOW00097-0

WARNING

Be sure to use cloth to remove fuel remaining in the cowl and dispose of it in accordance with local fire prevention and environment protection regulations.

1. Disconnect the fuel hose from the outboard motor.
2. Remove the top cowl.
3. Place an appropriate rag under the drain screw.
4. Loosen the carburetor drain screw.
5. Leave the outboard motor until all fuel has been drained.
6. When thoroughly drained, retighten the drain screw securely.
7. Check the drained fuel for the presence of contaminants. If it either is present, check the fuel filter and fuel in the fuel tank.

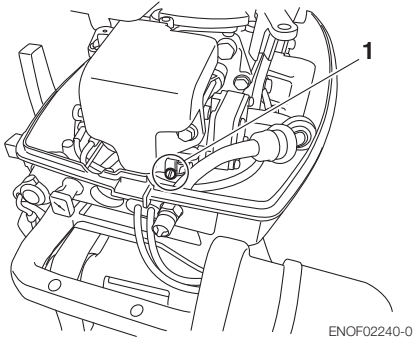

1. Carburetor drain screw

ENOM00104-E

4. Pre-season check

The following steps must be taken when first using the engine after off season storage.

1. Check that the shift and throttle function properly. (Be sure to turn the propeller shaft when checking the shift function or else the shift linkage may be damaged.)
2. Check the electrolyte level, and measure the voltage and specific gravity of the battery.

Specific Gravity at 20°	Terminal Voltage (V)	Charge Condition
1.120	10.5	Fully discharged
1.160	11.1	1/4 charged
1.210	11.7	1/2 charged
1.250	12	3/4 charged
1.280	13.2	Fully charged

3. Check that the battery is secure and the battery cables are properly installed.
4. Fill the fuel tank with oil and fuel.
5. Connect the fuel line to the engine, and squeeze primer bulb.
6. Before starting the engine, disconnect stop switch lock and crank approximately 10 pulling the recoil starter (Manual start model) or 3times of 3sec. turning the starter motor (Electric start model) in order to circulate the oil.
7. Start the engine and warm up the engine for 3 minutes in the "NEUTRAL" position.
8. Run the engine for 5 minutes at the slowest speed.
9. Run the engine for 10 minutes at half throttle. The oil used for storage inside the engine will be circulated out to assure optimum performance.

ENOM00105-D

5. Submerged outboard motor

ENOW00098-0

CAUTION

Do not attempt to start submerged outboard motor immediately after it is recovered, or engine could be severely damaged.

After taking your outboard motor out of the water, immediately take it to your dealer. The following are the emergency measures to be taken for a submerged outboard motor, if you can not take it your dealer right away.

1. Wash the outboard motor with fresh water to remove salt or dirt.
2. Remove the spark plugs, and completely drain the water from the engine by pulling recoil starter several times.
3. Inject a sufficient amount of engine oil through the spark plug holes. Pull the recoil starter rope several times to circulate the oil throughout the outboard motor.

ENOM00106-A

6. Cold weather precautions

If you moor your boat in cold weather at temperatures below 0°C (32°F), there is the danger of remained water freezing in the cooling water pump, which may damage the pump, impeller, etc. To avoid this problem, submerge the lower half of the outboard motor into the water.

10

ENOM00107-A

7. Striking underwater object

ENOW00935-0

 **CAUTION**

Striking the sea bottom or an underwater object may severely damage the outboard motor.

Follow the procedure below and consult a dealer as soon as possible.

1. Stop the engine immediately.
2. Check the control system, gear case, boat transom etc.
3. Return to the nearest harbor slowly and carefully.
4. Consult a dealer check the outboard motor before operation again.

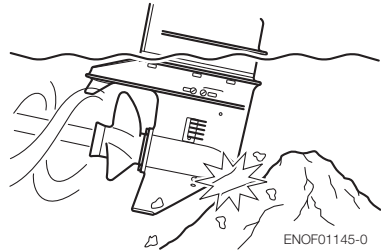

ENOM00120-0

8. Auxiliary outboard motor operation

When the auxiliary outboard motor will not be used, be sure to remove the stop switch lock, shift into forward, and then tilt the outboard motor up. Otherwise, over-rotation of the propeller due to water spray could damage the gear.

TROUBLESHOOTING

ENOM01505-0

If you encounter a problem, consult the check list below to determine the cause and to take the proper action.

An authorized dealer will always be happy to provide any assistance and information.

	Engine failing to start	Engine starting but stopping soon	Poor idling	Poor acceleration	Engine speed abnormally high	Engine speed abnormally low	High engine speeds not possible	Overheating of engine	Possible cause
FUEL SYSTEMS	●	●							Empty fuel tank
	●	●	●	●		●	●	●	Incorrect connection of fuel system
	●	●	●	●		●	●	●	Air entering fuel line
	●	●	●	●		●	●	●	Deformed or damaged fuel pipe
	●	●	●	●		●	●	●	Closed air vent on fuel tank
	●	●	●	●		●	●	●	Clogged fuel filter, fuel pump, or carburetor
			●	●		●	●	●	Use of improper engine oil
	●		●	●			●	●	Use of improper gasoline
	●	●	●	●		●	●		Excessive oil in mixture
								●	Shortage of oil in mixture
	●			●					Excessive supply of fuel
ELECTRIC SYSTEMS	●	●	●	●		●	●	●	Poor carburetor adjustment
	●	●	●	●		●	●	●	Recirculation pipe broken
	●	●	●	●		●	●	●	Spark plug other than specified
	●	●	●	●		●	●		Dirt, soot, etc. on spark plug
	●	●	●	●		●	●		No Spark or weak spark
	●								Short circuit of engine stop switch
	●		●	●		●	●		Incorrect adjustment of ignition timing
	●								Loose battery terminal connection, corrosion
	●								Discharged battery
	●								Main switch trouble
	●								Lock plate not fitted to stop switch
●								Disconnection of wire or loose ground connection	
●								Insufficient battery capacity, loose terminal connection, corrosion	

EF types

EF types

		Engine failing to start	Engine starting but stopping soon	Poor idling	Poor acceleration	Engine speed abnormally high	Engine speed abnormally low	High engine speeds not possible	Overheating of engine	Possible cause	
OTHERS	●			●	●		●	●		Incorrect adjustment of throttle link	
								●	●	Insufficient cooling water flow, clogged or defective pump	
				●					●	●	Faulty thermostat
					●	●			●	●	Cavitation or ventilation
					●	●	●	●	●	●	Incorrect propeller selection
			●		●	●	●	●	●	●	Damaged and bent propeller
					●	●			●	●	Improper thrust rod position
					●	●	●	●	●	●	Unbalanced load on boat
					●	●	●	●	●	●	Transom too high or too low

TOOL KIT AND SPARE PARTS

ENOM01506-0

The following a list of the tools and spare parts provided with the motor.

	Items	Quantity	Remark
Servicing Tools	Tool Bag	1	
	Pliers	1	
	Socket Wrench	1	10 x 13 mm
	Socket Wrench	1	21 mm
	Socket Wrench Handle	1	
	Screwdriver(Phillips-type and flat head)	1	Adapter-type
Spare Parts	Rope	1	1,000 mm
	Spark Plug	1	NGK BPR7HS-10
	Split Pin	1	
Parts Packaged with Engine*	Fuel Tank	1	
	Primer bulb	1 set	

* Not provided with the motor in some markets.

PROPELLER TABLE

ENOM00111-0

Use a genuine propeller.

A propeller must be selected so that the engine rpm measured at wide open throttle while cruising is within the recommended range.

Recommended range at WOT: 6B, 8B = 4,500 to 5,500 rpm
9.8B = 5,000 to 6,000 rpm

	Propeller Mark	Propeller Size (Diameter × pitch)		
		No. of Blades	inch	mm
Light boats Heavy boats	9.5	3	8.9 × 10	226 × 255
	8.5	3	8.9 × 8.3	226 × 211
	7.5	3	8.5 × 7.5	216 × 190
	7.0	3	8.9 × 7.0	226 × 178
	6.5	3	8.5 × 6.5	216 × 165



OWNER'S MANUAL

M 6B

M 8B

M 9.8B

MEMO



A series of 21 horizontal dashed lines for writing, evenly spaced across the page.

TOHATSU

en

OWNER'S MANUAL

fr

MANUEL DE L'UTILISATEUR

es

MANUAL DEL PROPIETARIO

pt

MANUAL DO PROPRIETÁRIO

zh

用户手册

ru

РУКОВОДСТВО ПОЛЬЗОВАТЕЛЯ

M 6B

M 8B

M 9.8B

TOHATSU CORPORATION

Address : 5-4, Azusawa 3-Chome, Itabashi-ku,
Tokyo, Japan

Phone : TOKYO +81-3-3966-3117

FAX : TOKYO +81-3-3966-2951

URL : www.tohatsu.co.jp