

OWNER'S MANUAL

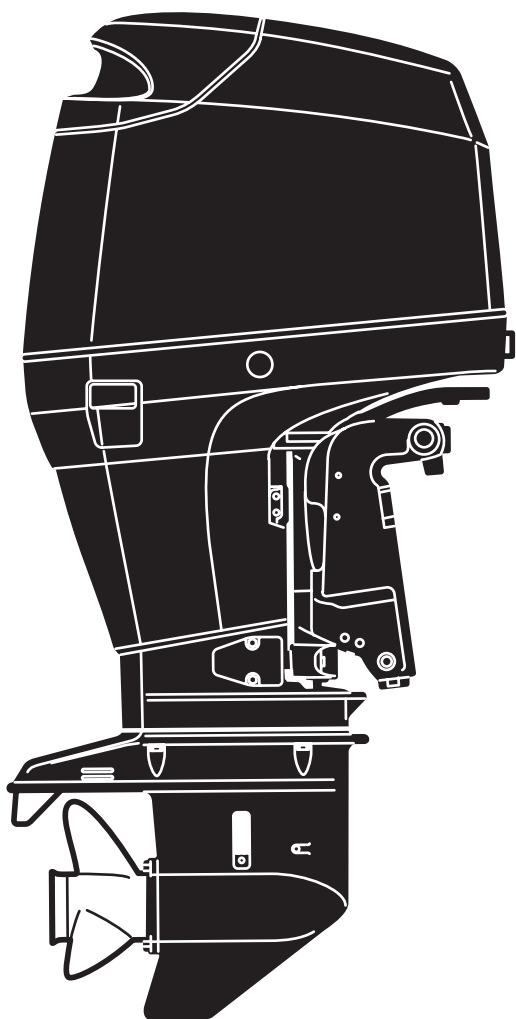

TOHATSU
Outboards

MD 30B2
40B2
50B2
75C2
90C2
115A2

OB No.003-11075-D

⚠ READ THIS MANUAL BEFORE USING THE OUTBOARD MOTOR. FAILURE TO FOLLOW THE INSTRUCTIONS AND SAFETY PRECAUTIONS IN THIS MANUAL CAN RESULT IN SERIOUS INJURY OR DEATH. KEEP THIS MANUAL IN A SAFE LOCATION FOR FUTURE REFERENCE.

Copyright © 2009-2012 Tohatsu Corporation. All rights reserved. No part of this manual may be reproduced or transmitted in any form or by any means without the express written permission of Tohatsu Corporation.

YOUR TOHATSU OUTBOARD MOTOR

OWNER REGISTRATION AND IDENTIFICATION

Upon purchasing this product, be sure that the WARRANTY CARD is correctly and completely filled out and mailed to the addressee noted there on. This WARRANTY CARD identifies you as the legal owner of the product and serves as your warranty registration.

TO THE EXTENT PERMITTED BY APPLICABLE LAW, YOUR OUTBOARD MOTOR WILL NOT BE COVERED BY THE APPLICABLE LIMITED WARRANTY, IF THIS PROCEDURE IS NOT FOLLOWED.

PRE-DELIVERY CHECK

Be sure that the product has been checked by an authorized TOHATSU dealer before you take delivery.

Limited Warranty

Please refer to the TOHATSU outboard motor Limited warranty provided to you with this product, the terms and conditions of which, as amended from time to time, are incorporated by reference into the manual.

Serial Number

In the space below, please record the outboard motor's serial number (indicated both on the lower motor cover and on the cylinder block). The serial number will be needed in the event of theft or to quickly identifying the outboard motor type.

Serial Number :

To You, Our Customer

Thank you for selecting a TOHATSU outboard motor. You are now the proud owner of an excellent outboard motor that will service you for many years to come.

This manual should be read in its entirety and the inspection and maintenance procedures described later in this manual should be followed carefully. Should a problem arise with the outboard motor, please follow the troubleshooting procedures listed at the end of this manual. If the problem persists, contact an authorized TOHATSU service shop or dealer.

We hope you will enjoy your outboard motor and wish you good luck in your boating adventures.

TOHATSU CORPORATION

CONTENTS

■	GENERAL SAFETY INFORMATION	8
1	SPECIFICATIONS	10
2	NAMES OF PARTS	15
3	LOCATIONS OF WARNING LABELS	20
4	INSTALLATION	21
	1. Mounting the outboard motor on boat	21
	2. Propeller Selection	24
	3. Installing the remote control devices	25
	4. Installing the meters	30
	5. Installing the drag link assembly	32
	6. Installing the battery	33
5	PRE-OPERATING PREPARATIONS	35
	1. Recommended gasoline types	35
	2. Low permeation fuel hose requirement	36
	3. EPA pressurized portable fuel tank requirements	37
	4. Recommended engine oil	38
	5. Break-in	40
	6. Warning system	41
6	ENGINE OPERATION	44
	1. Starting	44
	2. Warming up the engine	50
	3. Forward and reverse	51
	4. Shallow water running	53
	5. Stopping the engine	55
	6. Trim angle	57
	7. Mooring with the engine tilted up	60
7	REMOVING AND CARRYING THE OUTBOARD MOTOR	63
	1. Removing the outboard motor	63
	2. Carrying the outboard motor	63
	3. Storing the outboard motor	64
8	TRAILERING	65
9	ADJUSTMENT	66
	1. Remote control lever load	66
	2. Trim tab adjustment	66
	3. Steering load adjustment	67
	4. Throttle grip turning load adjustment	67
10	INSPECTION AND MAINTENANCE	68
	1. Daily inspection	69
	2. Periodic inspection	73
	3. Off-season storage	79

4. Pre-season check	81
5. Checking after striking underwater object	82
6. If the engine becomes submerged in water	82
7. Precautions in cold weather	82
11 TROUBLESHOOTING	83
12 TOOL KIT AND SPARE PARTS	85
13 OPTIONAL ACCESSORIES	87
14 PROPELLER TABLE	89

INDEX

GENERAL SAFETY INFORMATION

1. SPECIFICATIONS

1

2. NAMES OF PARTS

2

3. LOCATIONS OF WARNING LABELS

3

4. INSTALLATION

4

5. PRE-OPERATING PREPARATIONS

5

6. ENGINE OPERATION

6

7. REMOVING AND CARRYING THE OUTBOARD MOTOR

7

8. TRAILERING

8

9. ADJUSTMENT

9

10. INSPECTION AND MAINTENANCE

10

11. TROUBLESHOOTING

11

12. TOOL KIT AND SPARE PARTS

12

13. OPTIONAL ACCESSORIES

13

14. PROPELLER TABLE

14

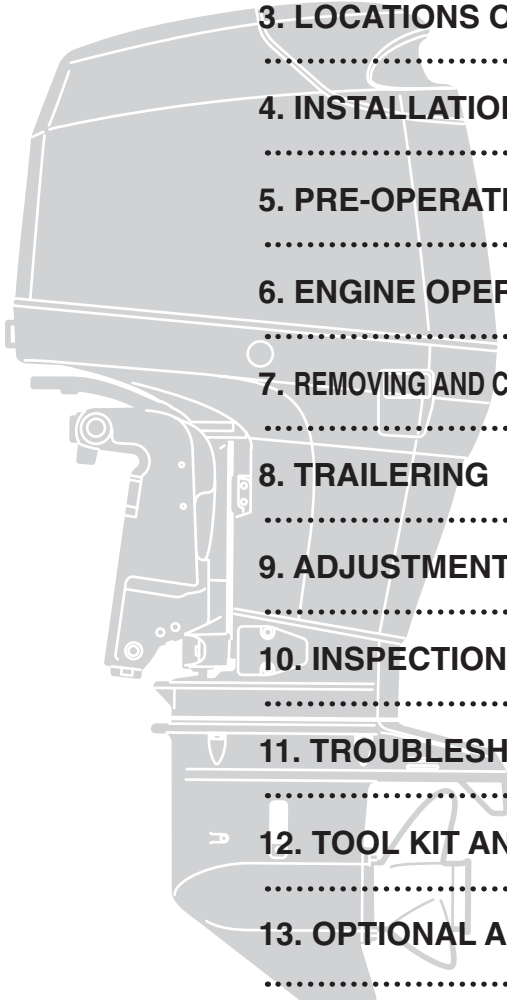

GENERAL SAFETY INFORMATION

NOTICE : DANGER/WARNING/CAUTION/Note

Before installing, operating or otherwise handling your outboard motor, be sure to thoroughly read and understand this Owner's Manual and carefully follow all of the instructions. Of particular importance is information preceded by the words "DANGER," "WARNING," "CAUTION," and "Note." Always pay special attention to such information to ensure safe operation of the outboard motor at all times.

DANGER

Failure to observe will result in severe personal injury or death, and possibly property damage.

WARNING

Failure to observe could result in severe personal injury or death, or property damage.

CAUTION

Failure to observe could result in personal injury or property damage.

Note

This instruction provides special information to facilitate the use or maintenance of the outboard motor or to clarify important points.

EMERGENCY STOP SWITCH

The Emergency Stop Switch will stall the outboard motor when the stop switch tether is pulled off. This stop switch tether can be attached to the operator of the outboard motor to minimize or prevent injuries from the propeller in case the operator falls overboard.

We highly recommend use of the Emergency Stop Switch tether.

WARNING

Accidental activation of the Emergency Stop Switch (such as the tether being pulled out in heavy seas) could cause passengers to lose their balance and even fall overboard, or it could result in loss of power in heavy seas, strong currents, or high winds. Loss of control while mooring is another potential hazard.

To minimize accidental activation of the Emergency Stop Switch, the 500 mm (20 inch.) stop switch tether is coiled and can extended to a full 1,300 mm (51 inch.).

SAFE OPERATION OF BOAT

As the operator/driver of the boat, you are responsible for the safety of those aboard and those in other boat around yours, and for following local boating regulations. You should be thoroughly knowledgeable on how to correctly operate the boat, outboard motor, and accessories. To learn about the correct operation and maintenance of the outboard motor, please read through this manual carefully. It is very difficult for a person standing or floating in the water to take evasive action should he or she see a power boat heading in his /her direction, even at a slow speed. Therefore, when your boat is in the immediate vicinity of people in the water, the outboard motor should be shifted to neutral and shut off.

WARNING

SERIOUS INJURY IS LIKELY IF A PERSON IN THE WATER MAKES CONTACT WITH A MOVING BOAT, GEAR HOUSING, PROPELLER, OR ANY SOLID DEVICE RIGIDLY ATTACHED TO A BOAT OR GEAR HOUSING.

SERVICING, REPLACEMENT PARTS & LUBRICANTS

We recommend that only an authorized service shop perform service or maintenance on this outboard motor. Be sure to use genuine parts, genuine lubricants, or recommended lubricants.

MAINTENANCE

As the owner of this outboard motor, you should be acquainted with correct maintenance procedures. It is the operator's responsibility to perform all safety checks and to ensure that all lubrication and maintenance instructions are complied with for safe operation. Please comply with all instructions concerning lubrication and maintenance. You should take the engine to an authorized dealer or service shop for periodic inspection at the prescribed intervals. Correct periodic maintenance and proper care of this outboard motor will reduce the chance of problems and limit overall operating expenses.

MOUNTING

Outboard motor mounting must be performed by trained service person(s) using lift or hoist with sufficient capacity.

SPECIFICATIONS

30B2 (Available in specific region), 40B2

MODEL		30B2		40B2	
		EPTO	EFTO	EFO	
Overall Length	mm (in)	630 (24.8)	1,120 (44.1)		
Overall Width	mm (in)	345 (13.6)	384 (15.1)		
Overall Height S-L-UL	mm (in)	1,227 (48.3) · 1,354 (53.3) · 1,481 (58.3)			
Transom Height S-L-UL	mm (in)	403 (15.9) · 530 (20.9) · 657 (25.9)			
Weight	S kg (lb)	-	-	-	
	L kg (lb)	94.5 (208)	97.5 (215)	89.5 (197)	
	UL kg (lb)	-	-	-	
Output	kW (Hp)	22.1 (30)		29.4 (40)	
Max. Operating Range	rpm	4,750 - 5,750			
Engine Type		Direct fuel injection			
Number of Cylinder		3			
Bore × Stroke	mm (in)	68 × 64 (2.68 × 2.52)			
Piston Displacement	mL (Cu in)	697 (42.5)			
Exhaust System		Through hub exhaust			
Emission Controls		EC (Electronic Control)			
Cooling System		Water cooling			
Engine Lubrication		Oil injection			
Starting System		Electric starter motor			
Ignition System		Inductive Ignition			
Spark Plug		NGK IZFR6Q			
Alternator		12V,280W (Max.)			
Trim Position		4		6	
Engine Oil		Genuine Motor Oil or recommended one			
Gear Oil		Genuine Gear Oil or API GL5, SAE #80 to #90, approx. 500mL			
Fuel Tank Capacity	L (US gal)	25 (6.6)			
Engine Oil Capacity	L (US gal)	Approx. 2.0 (0.53)			
Gear Reduction Ratio		1.85 (13 : 24)			
Fuel		Unleaded regular gasoline : Pump posted 87 Octane (research octane rating of 91)			
Emission Control System		DI, EC (Electronic engine Control)			
Operator Sound Pressure (ICOMIA 39/94) dB(A)		84.0			
Hand Vibration Level (ICOMIA 38/94) m/sec ²		—	3.8		

※ This specifications might change without a previous notice.

50B2

1

Item		MODEL	50B2		
			EPTO	EFTO	EFO
Overall Length	mm (in)	630 (24.8)	1,120 (44.1)		
Overall Width	mm (in)	345 (13.6)	384 (15.1)		
Overall Height S-L-UL	mm (in)	1,227 (48.3) · 1,354 (53.3) · 1,481 (58.3)			
Transom Height S-L-UL	mm (in)	403 (15.9) · 530 (20.9) · 657 (25.9)			
Weight	S kg (lb)	93.5 (206)	96.5 (213)	88.5 (195)	
	L kg (lb)	94.5 (208)	97.5 (215)	89.5 (197)	
	UL kg (lb)	97 (214)	100 (220)	92 (203)	
Output	kW (Hp)	29.4 (40)		36.8 (50)	
Max. Operating Range	rpm	5,150 - 5,850			
Engine Type		Direct fuel injection			
Number of Cylinder		3			
Bore × Stroke	mm (in)	68 × 64 (2.68 × 2.52)			
Piston Displacement	mL (Cu in)	697 (42.5)			
Exhaust System		Through hub exhaust			
Emission Controls		EC (Electronic Control)			
Cooling System		Water cooling			
Engine Lubrication		Oil injection			
Starting System		Electric starter motor			
Ignition System		Inductive Ignition			
Spark Plug		NGK IZFR6Q			
Alternator		12V,280W (Max.)			
Trim Position		4		6	
Engine Oil		Genuine Motor Oil or recommended one			
Gear Oil		Genuine Gear Oil or API GL5, SAE #80 to #90, approx. 500mL			
Fuel Tank Capacity	L (US gal)	25 (6.6)			
Engine Oil Capacity	L (US gal)	Approx. 2.0 (0.53)			
Gear Reduction Ratio		1.85 (13 : 24)			
Fuel		Unleaded regular gasoline : Pump posted 87 Octane (research octane rating of 91)			
Emission Control System		DI, EC (Electronic engine Control)			
Operator Sound Pressure (ICOMIA 39/94) dB(A)		81.7			
Hand Vibration Level (ICOMIA 38/94) m/sec ²		—		3.8	

※ This specifications might change without a previous notice.

W50B2

Item		MODEL	W50B2	
			EPTO	EFTO
Overall Length	mm (in)		630 (24.8)	1,120 (44.1)
Overall Width	mm (in)		345 (13.6)	384 (15.1)
Overall Height L·UL	mm (in)		1,415 (55.7) · 1,542 (60.7)	
Transom Height L·UL	mm (in)		550 (21.7) · 677 (26.7)	
Weight	L kg (lb)		100.5 (222)	103.5 (228)
	UL kg (lb)		101.5 (224)	104.5 (230)
Output	kW (Hp)		36.8 (50)	
Max. Operating Range	rpm		5,150 - 5,850	
Engine Type			Direct fuel injection	
Number of Cylinder			3	
Bore × Stroke	mm (in)		68 × 64 (2.68 × 2.52)	
Piston Displacement	mL (Cu in)		697 (42.5)	
Exhaust System			Through hub exhaust	
Emission Controls			EC (Electronic Control)	
Cooling System			Water cooling	
Engine Lubrication			Oil injection	
Starting System			Electric starter motor	
Ignition System			Inductive Ignition	
Spark Plug			NGK IZFR6Q	
Alternator			12V,280W (Max)	
Trim Position			4	
Engine Oil			Genuine Motor Oil or recommended one	
Gear Oil			Genuine Gear Oil or API GL5, SAE #80 to #90, approx. 700mL	
Fuel Tank Capacity	L (US gal)		25 (6.6)	
Engine Oil Capacity	L (US gal)		Approx. 2.0 (0.53)	
Gear Reduction Ratio			1.92 (12 : 23)	
Fuel			Unleaded regular gasoline : Pump posted 87 Octane (research octane rating of 91)	
Emission Control System			DI, EC (Electronic engine Control)	
Operator Sound Pressure (ICOMIA 39/94) dB(A)			84.0	
Hand Vibration Level (ICOMIA 38/94) m/sec ²			—	3.8

※ This specifications might change without a previous notice.

75C2 , 90C2

1

Item		MODEL	75C2	90C2
		EPTO		
Overall Length	mm (in)	810 (31.9)		
Overall Width	mm (in)	508 (20.0)		
Overall Height L·UL	mm (in)	1,540 (60.6) · 1,667 (65.6)		
Transom Height L·UL	mm (in)	517 (20.4) · 644 (25.4)		
Weight	L·UL kg (lb)	152 (335) · 155 (342)		
Output	kW (Hp)	55.2 (75)	66.2 (90)	
Max. Operating Range	rpm	5,150 - 5,850		
Engine Type		Direct fuel injection		
Number of Cylinder		3		
Bore × Stroke	mm (in)	86 × 72.7 (3.39 × 2.86)		
Piston Displacement	mL (Cu in)	1,267		
Exhaust System		Through hub exhaust		
Emission Controls		EC (Electronic Control)		
Cooling System		Water cooling		
Engine Lubrication		Oil injection		
Starting System		Electric starter motor		
Ignition System		Inductive ignition		
Spark Plug		NGK IZFR6Q		
Alternator		12V,490W (Max.)		
Trim Position		2		
Engine Oil		Genuine Motor Oil or recommended one		
Gear Oil		Genuine Gear Oil or API GL5, SAE #80 to #90, approx. 900mL		
Fuel Tank Capacity	L (US gal)	—		
Engine Oil Capacity	L (US gal)	4L		
Gear Reduction Ratio		2.33 (12:28)		
Fuel		Unleaded regular gasoline : Pump posted 87 Octane (research octane rating of 91)		
Emission Control System		DI, EC (Electronic engine Control)		
Operator Sound Pressure (ICOMIA 39/94) dB(A)		81.7		
Hand Vibration Level (ICOMIA 38/94) m/sec ²		—		

※ This specifications might change without a previous notice.

115A2

Item	MODEL	115A2
		EPTO
Overall Length	mm (in)	800 (31.5)
Overall Width	mm (in)	495 (19.5)
Overall Height L·UL	mm (in)	1,640 (64.6) · 1,767 (69.6)
Transom Height L·UL	mm (in)	517 (20.4) · 644 (25.4)
Weight	L·UL kg (lb)	178 (392) · 181 (399)
Output	kW (Hp)	84.6 (115)
Max. Operating Range	rpm	5,150 - 5,850
Engine Type		Direct fuel injection
Number of Cylinder		4
Bore × Stroke	mm (in)	88 × 72.7 (3.46 × 2.86)
Piston Displacement	mL (Cu in)	1,768 (107.9)
Exhaust System		Through hub exhaust
Emission Controls		EC (Electronic Control)
Cooling System		Water cooling
Engine Lubrication		Oil injection
Starting System		Electric starter motor
Ignition System		Inductive ignition
Spark Plug		NGK IZFR5J
Alternator		12V,490W (Max.)
Trim Position		2
Engine Oil		Genuine Motor Oil or recommended one
Gear Oil		Genuine Gear Oil or API GL5, SAE #80 to #90, approx. 900mL
Fuel Tank Capacity	L (US gal)	-
Engine Oil Capacity	L (US gal)	Approx. 6.7 (1.77)
Gear Reduction Ratio		2.0 (13:26)
Fuel		Unleaded regular gasoline : Pump posted 87 Octane (research octane rating of 91)
Emission Control System		DI, EC (Electronic engine Control)
Operator Sound Pressure (ICOMIA 39/94) dB(A)		83.3
Hand Vibration Level (ICOMIA 38/94) m/sec ²		—

※ This specifications might change without a previous notice.

■ NAMES OF PARTS

EFO / 40B2 , 50B2

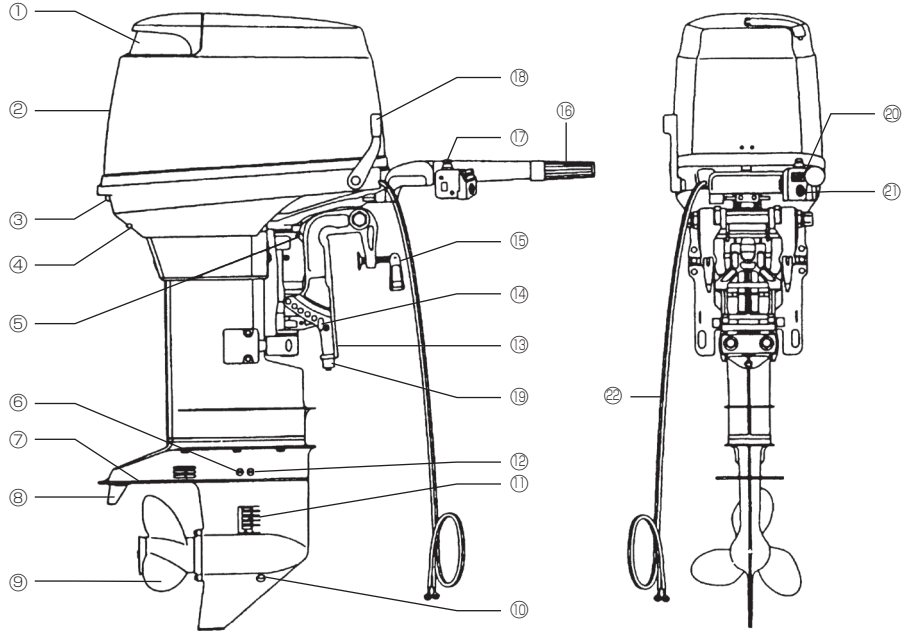

2

- | | | |
|--------------------------|--------------------|-----------------|
| ① Tilt Handle | ⑨ Propeller | ⑰ Stop Switch |
| ② Top Cowl | ⑩ Oil Plug (lower) | ⑱ Shift Lever |
| ③ Hook Lever | ⑪ Water Inlet | ⑲ Anode |
| ④ Water Check Port | ⑫ Oil Plug(upper) | ⑳ Pilot Lamp |
| ⑤ Reverse Lock Lever | ⑬ Clamp Bracket | ㉑ Main Switch |
| ⑥ Water Plug | ⑭ Thrust Rod | ㉒ Battery Cords |
| ⑦ Anti-ventilation Plate | ⑮ Clamp Screw | |
| ⑧ Trim Tab | ⑯ Throttle Grip | |

EFTO / 30B2 , 40B2 , 50B2 , W50B2

2

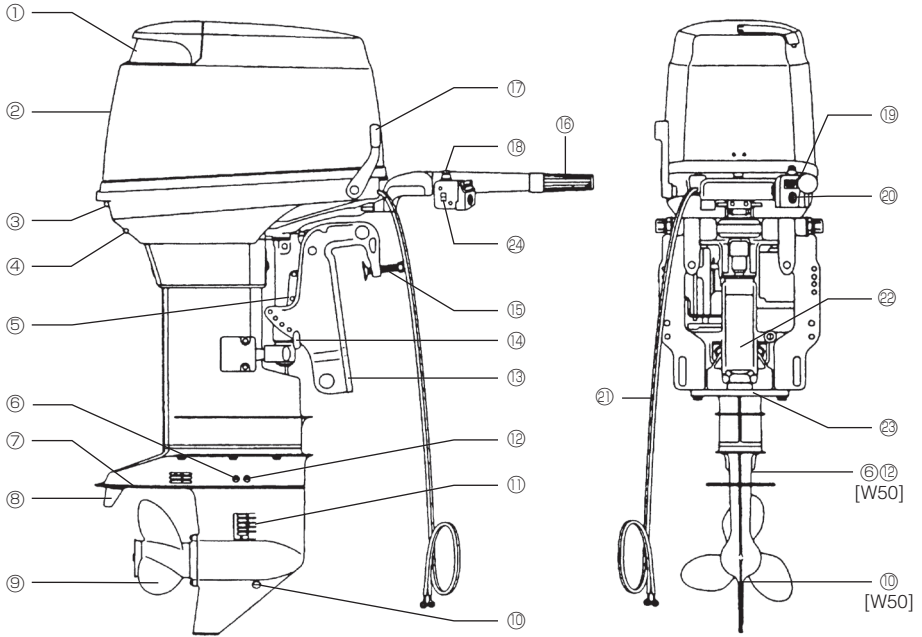

- | | | |
|--------------------------|--------------------|----------------------------|
| ① Tilt Handle | ⑨ Propeller | ⑰ Shift Lever |
| ② Top Cowl | ⑩ Oil Plug (lower) | ⑱ Stop Switch |
| ③ Hook Lever | ⑪ Water Inlet | ⑲ Pilot Lamp |
| ④ Water Check Port | ⑫ Oil Plug(upper) | ⑳ Main Switch |
| ⑤ Tilt Stopper | ⑬ Clamp Bracket | ㉑ Battery Cords |
| ⑥ Water Plug | ⑭ Thrust Rod | ㉒ Power Trim & Tilt |
| ⑦ Anti-ventilation Plate | ⑮ Clamp Screw | ㉓ Anode |
| ⑧ Trim Tab | ⑯ Throttle Grip | ㉔ Power Trim & Tilt Switch |

EPTO / 30B2 , 40B2 , 50B2 , W50B2

2

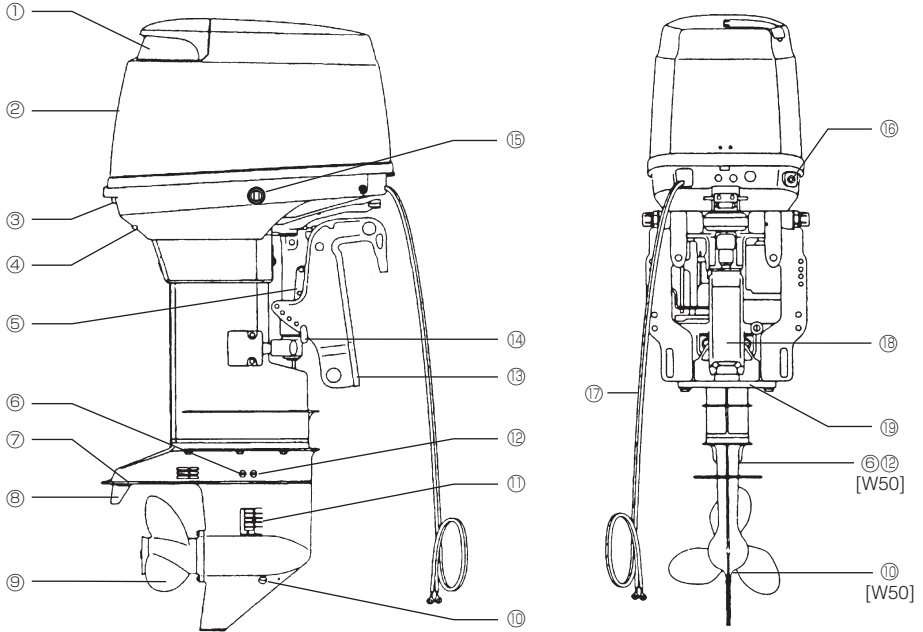

- ① Tilt Handle
- ② Top Cowl
- ③ Hook Lever
- ④ Water Check Port
- ⑤ Tilt Stopper
- ⑥ Water Plug
- ⑦ Anti-ventilation Plate
- ⑧ Trim Tab
- ⑨ Propeller
- ⑩ Oil Plug (lower)
- ⑪ Water Inlet
- ⑫ Oil Plug(upper)
- ⑬ Clamp Bracket
- ⑭ Thrust Rod
- ⑮ Power Trim & Tilt Switch
- ⑯ Fuel Connector

- ⑰ Battery Cords
- ⑱ Power Trim & Tilt
- ⑲ Anode

EFTO / 75C2 , 90C2

2

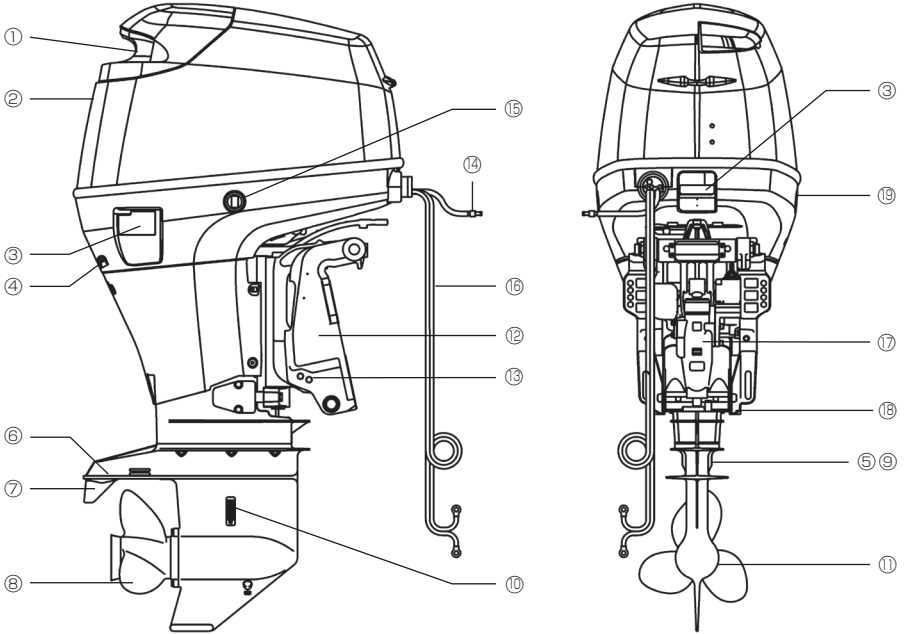

- | | | |
|--------------------------|----------------------------|--------------------------|
| ① Tilt Handle | ⑨ Oil Plug (upper) | ⑰ Power Trim & Tilt |
| ② Top Cowl | ⑩ Water Inlet | ⑱ Anode |
| ③ Hook Lever | ⑪ Oil Plug (lower) | ⑲ Flushing Connector Cap |
| ④ Water Check Port | ⑫ Clamp Bracket | |
| ⑤ Water Plug | ⑬ Thrust Rod | |
| ⑥ Anti-ventilation Plate | ⑭ Fuel Nose Nipple | |
| ⑦ Trim Tab | ⑮ Power Trim & Tilt switch | |
| ⑧ Propeller | ⑯ Battery Cords | |

EPTO / 115A2

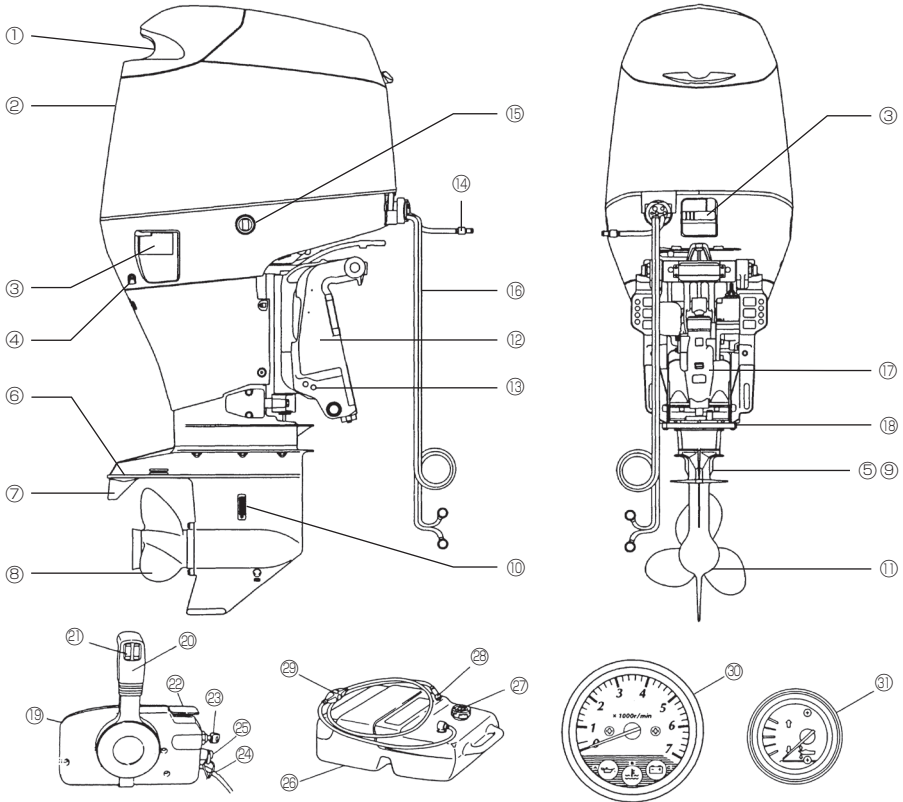

○ Note

These parts for model 115A2 are not enclosed in the engine package.

- | | | |
|--------------------------|----------------------------|------------------|
| ① Tilt Handle | ⑬ Clamp Bracket | ⑳ Main Switch |
| ② Top Cowl | ⑭ Thrust Rod | ㉑ Harness B |
| ③ Hook | ⑮ Fuel Nose Nipple | ㉒ Stop Switch |
| ④ Water Check Port | ⑯ Power Trim & Tilt switch | ㉓ Fuel Tank |
| ⑤ Water Plug | ⑰ Battery Cords | ㉔ Air Vent Screw |
| ⑥ Anti-ventilation Plate | ⑱ Power Trim & Tilt | ㉕ Fuel Connector |
| ⑦ Trim Tab | ⑲ Anode | ㉖ Primer Bulb |
| ⑧ Propeller | ⑳ Remote Control Box | ㉗ Tachometer |
| ⑨ Oil Plug (upper) | ㉑ Remote Control Lever | ㉘ Trim Meter |
| ⑩ Water Inlet | ㉒ Power Trim & Tilt Switch | |
| ⑪ Oil Plug (lower) | ㉓ Free Accel Lever | |

LOCATIONS OF WARNING LABELS

Locations of warning labels

Warning label regarding owner's manual, top cowl, engine stop switch, engine oil level and unleaded gasoline

3

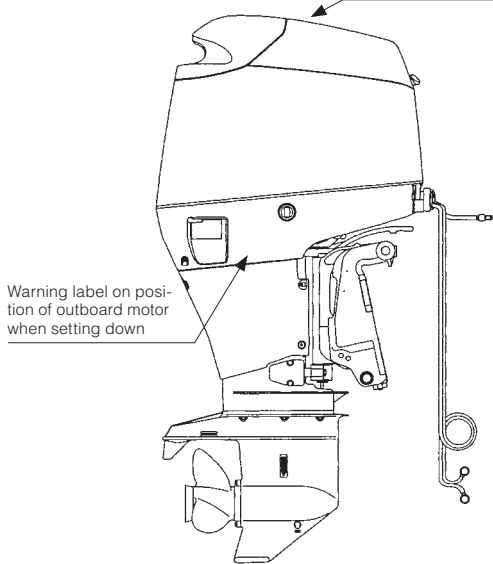

Warning label on position of outboard motor when setting down

WARNING 警告

- Read owner's manual very carefully before operating this motor. Give special attention to safety cautions.
- Lire très soigneusement le Manuel d'entretien avant de démarrer ce moteur. Faire très attention aux mesures de sécurité.
- Bedenungsanleitung vor der Inbetriebnahme sorgfältig lesen. Beachten Sie besonders die Sicherheitsvorschriften!
- ご使用前に必ず取扱説明書をお読み下さい。

Never remove or replace the motor cover while the engine is running.

Nie jamais déposer ou remettre le capot du moteur quand le moteur tourne.

Niessen des Motorschutzes während des Motorlaufs ansetzen!

エンジン運転中はモーターカバーを外さないで下さい。

Be sure to connect the emergency stop line to your wrist.

Assurez-vous que le cordon de sécurité soit bien attaché à votre poignet.

Versichern Sie sich, dass die Notstopleine an Ihrem Handgelenk befestigt ist.

運転者緊急停止スイッチの危険あり

*運転中はエンジンストップスイッチコードを身体の一部に必ずつけて下さい。

Check oil level before starting.

Obstaud vor dem Motorstart untersuchen!

Vérifier le niveau d'huile avant de démarrer.

運転前にエンジンオイルの油位を確認。

Unleaded fuel only.

Nur unverbleites Benzin verwenden.

Essence sans plomb uniquement.

無鉛ガソリンを使用して下さい。

WARNING 警告

- Be sure to connect the emergency stop line to your wrist.
- Assurez-vous que le cordon de sécurité soit bien attaché à votre poignet.
- Versichern Sie sich, dass die Notstopleine an Ihrem Handgelenk befestigt ist.
- 運転者緊急停止スイッチの危険あり

*運転中はエンジンストップスイッチコードを身体の一部に必ずつけて下さい。

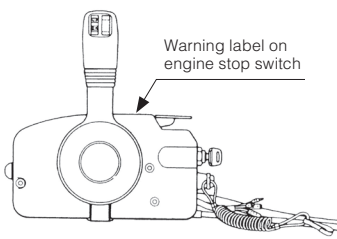

Warning label on engine stop switch

up 保管・運搬時はこちら側を上において下さい
This side up for transport or storage.

CAUTION

Never open the fuel tank cap when the engine is running.

運転中に燃料タンクのキャップを開かないでください。

Only for USA and CANADA models
Warning regarding combination of fuel tank and primer bulb ass'y.

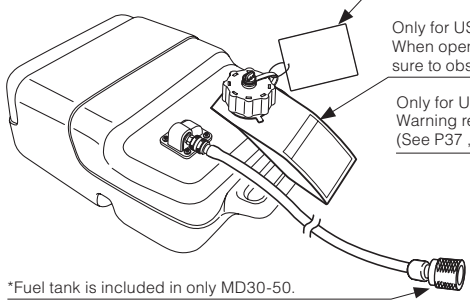

Only for USA and CANADA models
When opening or closing fuel tank cap, be sure to observe warning note on fuelling

Only for USA and CANADA models
Warning regarding fuel tank cap (See P37 ,P44 -P56)

*Fuel tank is included in only MD30-50.

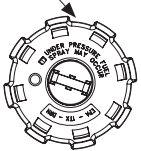

STOP

Do not remove the fuel tank cap when the engine is running.

運転中に燃料タンクのキャップを開かないでください。

Do not use the primer bulb when the engine is running.

運転中にプライマーバルブを使用しないでください。

Do not use the fuel tank cap when the engine is running.

運転中に燃料タンクのキャップを開かないでください。

Do not use the primer bulb when the engine is running.

運転中にプライマーバルブを使用しないでください。

Do not use the fuel tank cap when the engine is running.

運転中に燃料タンクのキャップを開かないでください。

Do not use the primer bulb when the engine is running.

運転中にプライマーバルブを使用しないでください。

Individual symbol marks means as described below.

Warning/ Caution 	Read manual thoroughly. 	Check oil level. 	Use unleaded gasoline only. 	Lay as indicated. 	Flammable - Keep Fire Away.
----------------------	-----------------------------	----------------------	---------------------------------	-----------------------	---------------------------------

INSTALLATION

1. Mounting the outboard motor on boat

WARNING

Most boats are rated and certified in terms of their maximum allowable horsepower, as shown on the boat's certification plate. Do not equip your boat with an outboard motor that exceeds this limit. If in doubt, contact your dealer. Do not operate the outboard motor until it has been securely mounted on the boat in accordance with the instructions below.

Note

Consult your authorized dealer to receive the proper instructions or ask your dealer to mount the motor as necessary.

Installation

■ Single-engine Installation

Position the outboard engine at the exact center of the stern, and mount it using a cushioning pad or plate.

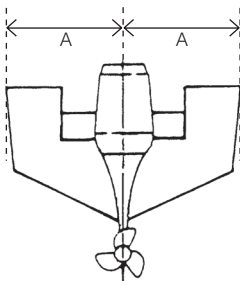

■ Twin-engine Installation

When installing two outboard engines, be sure to keep an interval of 470~660mm (for 30,40 and 50 models) or 700~890mm (for 75,90 and 115 model) between the two.

30 - 50 : 470 - 660mm
(18.5 - 26.0 in)
75 - 115 : 700 - 890mm
(27.6 - 35.0 in)

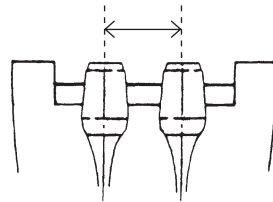

CAUTION

- Before beginning the running test, check that the boat with maximum capacity loading floats on the water in a proper attitude. Check the position of water surface on the driveshaft housing. If the water surface is near the bottom cowling, in high waves, water may enter the engine cylinders.
- Incorrect outboard motor mounting height or existence of underwater object(s), such as hull bottom design, bottom surface conditions or underwater accessories, can cause water spray possibly reaching the engine through an opening of the bottom cowling during cruising. Exposing engine to such conditions for extended periods can lead to severe engine damage.

■ **Transom Height**

Install the engine with the Anti-ventilation Plate at a level 10~30mm(0.4~1.2in.) below the bottom of the boat.

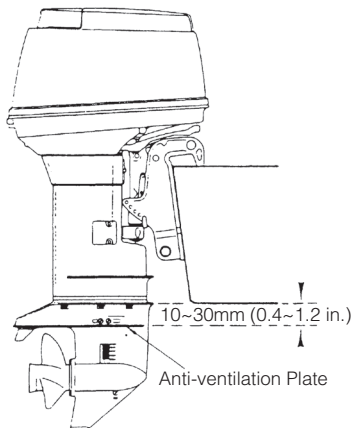

■ **Transom Matching**

Be sure that anti ventilation plate of the outboard is below the water surface when running with wide open throttle.

In case the above condition cannot be met due to the shape of your boat, please consult your authorized dealer.

CAUTION

Overheating may occur if the Anti-ventilation Plate is at a level higher than the bottom of the boat, as a result of a lack of cooling water.

If the height difference exceeds 10~30mm (0.4~1.2 in) engine power performance is likely to be reduced as a result of increased water resistance to the gear case assembly.

■ **Attaching the Clamp Bracket**

After positioning the Clamp Bracket, fix it with clamp screw then drill four holes in the transom board, matching the holes in the Clamp Bracket. Secure the engine with the supplied bolts (M12×105mm) and nuts, Be sure to use the washers. Use the larger diameter washers inside of the transom board and use the small diameter washers outside of the clamp bracket.

The mounting holes may be drilled beforehand by referring to the dimensional drawing.

WARNING

- Mounting the outboard motor without following this manual can lead to unsafe conditions such as poor maneuverability, going out of control or fire disaster.
- Loose clamp screws and/or mounting bolts can lead to the release or displacement of the outboard motor, possibly resulting in lost of control and/or serious personal injury. Be sure that fasteners are tightened to the specified torque (30 Nm (3.0kgf)13ft·lb). Check the fasteners for tightness from time to time.
- Be sure to use outboard mounting fasteners included in the outboard motor package or their equivalents in terms of size, material, quality and strength.
Tighten fasteners to the specified torque (30 Nm (3.0kgf)13ft·lb). Test cruise to check if fasteners are tightened securely.
- Outboard motor mounting must be performed by trained service person(s) using lift or hoist with sufficient capacity.

Clamp Bracket Dimensional Drawing

■ manual tilting type
EFO 40, 50

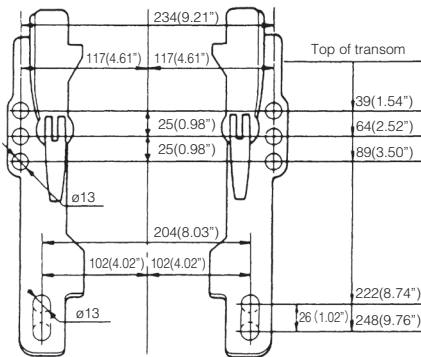
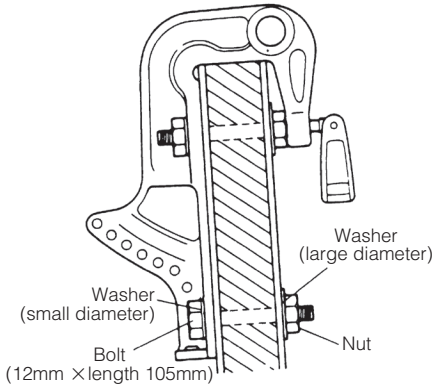

■ with the Power Trim and Tilt type
EFTO, EPTO 30, 40, 50

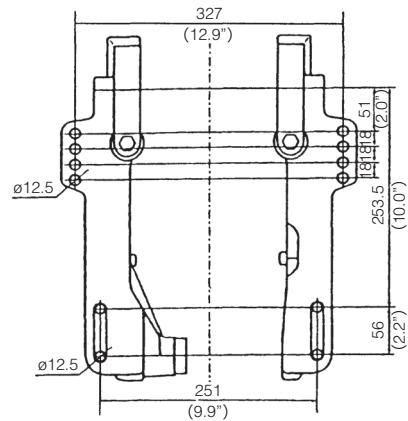
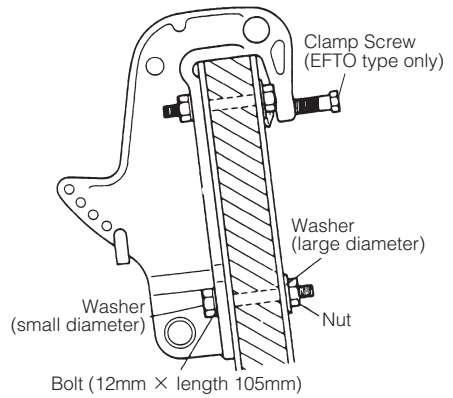

○ Note

It is recommended to install upper mounting bolts with bolt head at inside surface of transom. Bolts with threaded end at inside surface of transom can cause personal injury.

■ Power Trim and Tilt type
EPTO 75, 90, 115

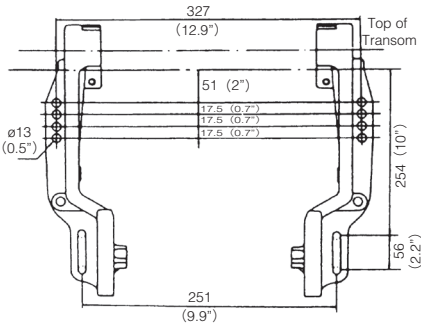
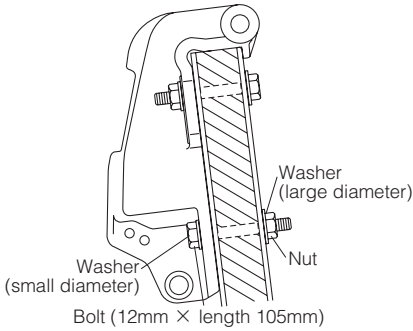

○ Notes

1. Apply sealing agent such as silicon sealer between bolts and transom board holes before tightening bolts.
2. Be sure to tighten mounting bolt nuts to specified torque.

2. Propeller Selection

A propeller must be selected so that the engine rpm measured at wide open throttle while cruising is within the max. operating range;
 5,150 to 5,850 rpm
 For genuine propellers, refer to Propeller Table of this manual.

○ Notes

The 75, 90,115 model is supplied with no standard propeller. In other words, it is shipped from the factory without a propeller.

3. Installing the remote control devices

⚠ WARNING

When using other than Tohatsu's genuine remote control box, DO NOT select the one without neutral safety switch that prevents in-gear start. Use of remote control box without neutral safety switch can allow start of engine with gear at other than neutral shift, potentially leading passengers to falling or causing passenger to be thrown overboard.

30, 40, 50

It is recommended that you consult with your authorized dealer for installation adjustment of the remote control device.

■ Installation of the Remote Control Cables (Box side) :

Follow the instruction manual provided with the remote control box.

■ Installation of the Remote Control Box on your boat :

Follow the instruction manual provided with the remote control box.

■ Connecting the Remote Control Cable to the engine [40, 50] :

- ① Detach the top cowl by turning the lever.

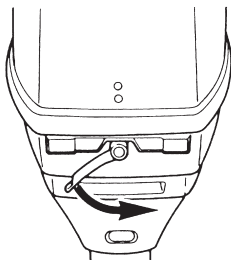

- ② Detach the bracket and Grommet. Put Remote Control Cables through the hole of upper grommet. And then set Cord Ass'y B and Meter lead wire (in case of use meter) on hollow of the lower grommet. Having fixed the Remote Control Cables to the bracket, tie them to the bottom cowl.

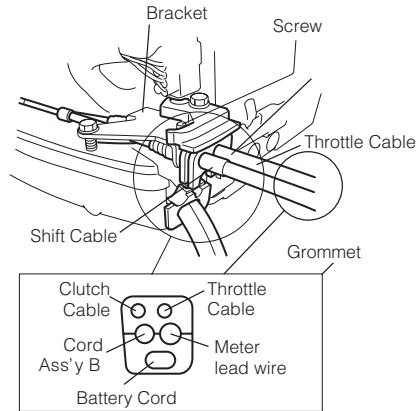

⚠ CAUTION

Be careful not to loop the remote control cables to a diameter of 406 mm (16 inches) or less.

- ③ Detach the throttle and shift cable joints by removing the R-shaped pins.

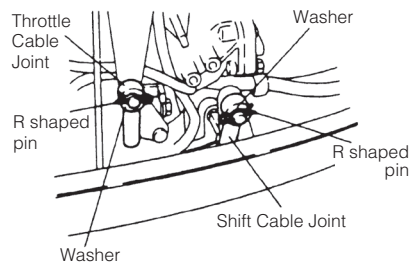

- ③ Screw the tip of the remote control cable into the cable joint up to approx. 10mm (0.39inch), then lock them with a lock nut. Apply grease to the hole of the cable joint.

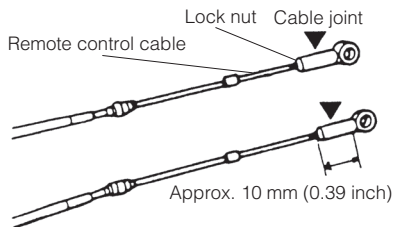

- ④ Move the Remote Control lever Forward, to Neutral and to Reverse to confirm the shift is working, and then set the lever to Neutral.
- ⑤ Double-check that the Remote Control Cables, the throttle cable and shift cable have been connected correctly. Move the Remote Control Lever Forward until the first engaging point (approx 32°). The cable which is moved first when the lever is turned is a shift cable. Check that

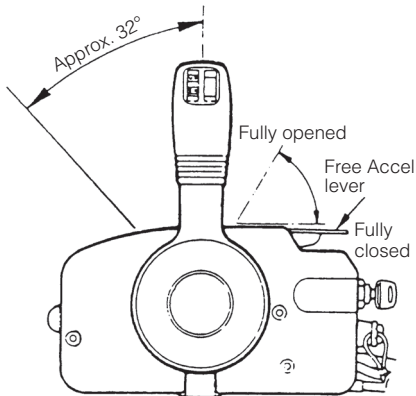

the shift lever is in Neutral and the Free Accel lever is fully closed when the remote control cables have been connected.

- ⑤ Set the shift arm to the Neutral(N) position and close the advancer arm completely. If the advancer arm does not contact with the stopper, the throttle position sensor will be active improperly.
- ⑥ The advancer arm should have contact with the stopper at neutral position of the remote control lever.

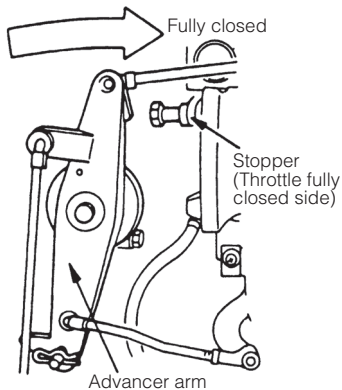
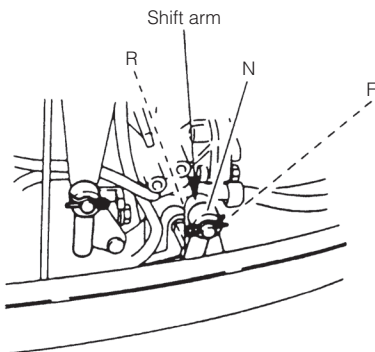

- ⑥ Adjust the cable joint (shift side) so that the hole meets with the shift arm pin, and lock the cable joint with the nut, and insert the shift arm pin and then secure with a washer and R-shaped pin. Also, adjust the cable joint (throttle side) so that the hole meets with the advancer arm pin, and lock the cable joint with the nut, and insert the advancer arm pin and then secure with a washer and R-shaped pin.

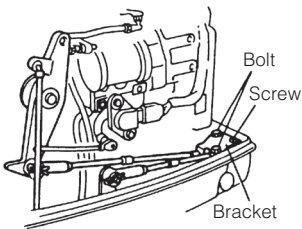
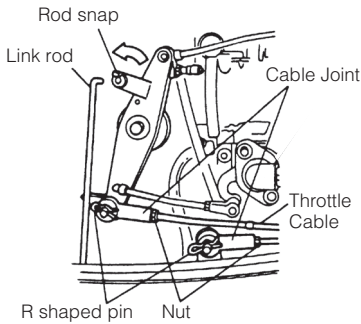

- ⑦ Place and fix Cable harness B to P.T. switch bracket as shown.

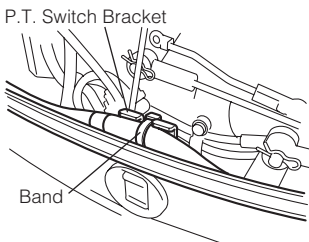

Connecting the Remote Control Cable to the engine [75, 90, 115]

- ① Turn the three hook levers fastening the bottom cowl and then remove the top cowl.
- ② Remove the hose clamp fastening the cord grommet. Remove the bolts fastening the cord clamp and then remove the cord clamp and the cord grommet.

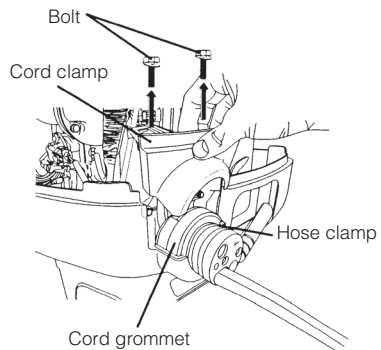
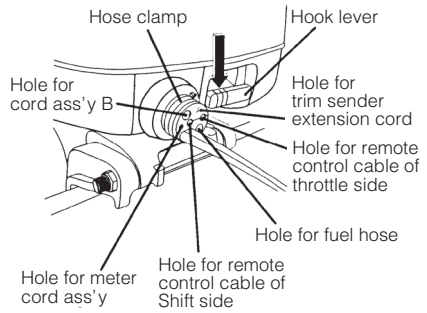

- ③ Detach the throttle and shift cable Joints by removing the R-shaped pins.

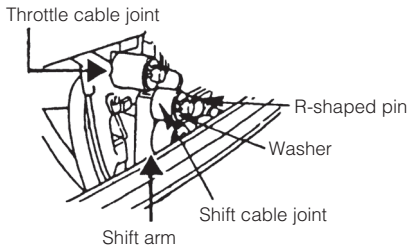

Move the shift arm Forward, to Neutral and to Reverse to confirm the shift is working, and then set the shift arm to Neutral.

- ④ Screw the tip of the remote control cable into the cable joint up to approx. 10mm(0.39inch), then lock them with a lock nut. Here, apply grease to the hole of the cable joint.

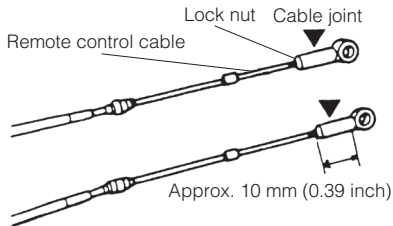

- ④ Move the Remote Control lever Forward, to Neutral and to Reverse to confirm the shift is working, and then set the lever to Neutral.
- ⑤ Double-check that the Remote Control Cables, the throttle cable and shift cable have been connected correctly. Move the Remote Control Lever Forward until the first engaging point (approx. 32°). The cable which is moved first when the lever is turned is a shift cable. Check that the shift lever is in Neutral and the Free Accel lever is fully closed

when the remote control cables have been connected.

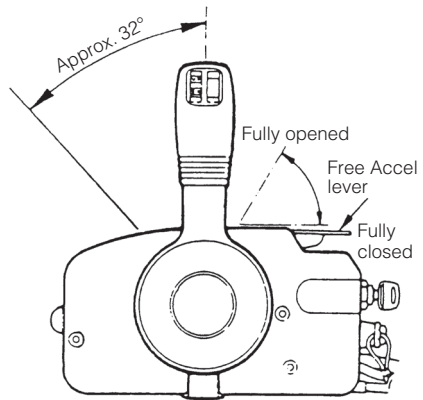

- ⑤ Set the shift arm to the Neutral(N) position and close the advancer arm completely.

If the advancer arm does not contact with the stopper, the throttle position sensor will be active improperly.

- ⑥ The advancer arm should have contact with the stopper at neutral position of the remote control lever.

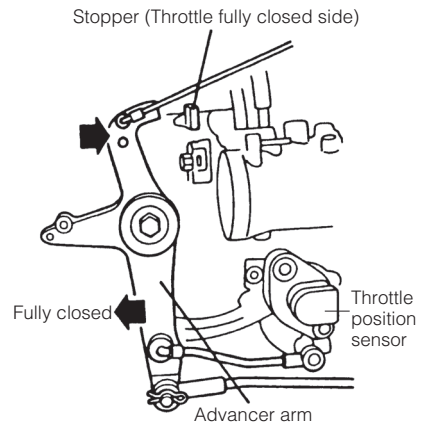

- ⑥ Install the hose clamp to the cord grommet.
Install the cord clamp.

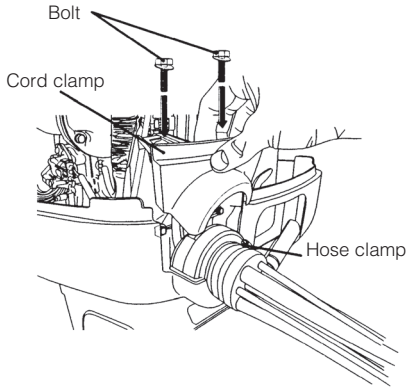

- ⑦ Adjust the cable joint (shift side) so that the hole meets with the shift arm pin, and lock the cable joint with the nut, and insert the shift arm pin and then secure with a washer and R-shaped pin. Also, adjust the cable joint (throttle side) so that the hole meets with the advancer arm pin, and lock the cable joint with the nut, and insert the advancer arm pin and then secure with a washer and R-shaped pin.

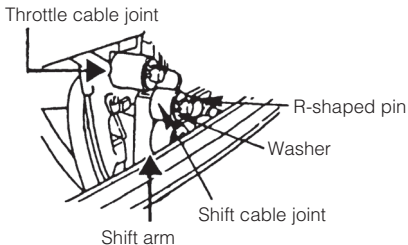

Connecting Cords and cable [30/40/50]

- ① Connect cable harness B and meter lead wire to cable harness A.

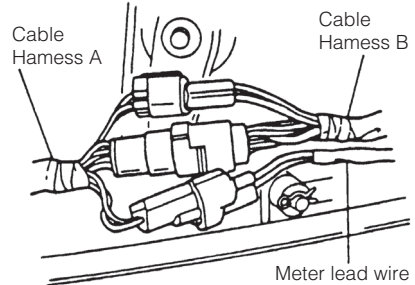

- ② Place and fix Cable harness B to P.T. switch bracket as shown.

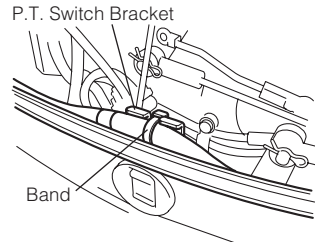

- ③ Connect the trim sender and the extension cable trim sensor.

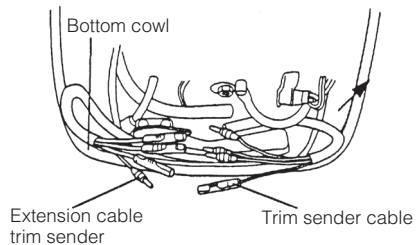

⚠ CAUTION

Do not disconnect the electric couplers while the engine is running, as this will damage the C.D. unit and could result in a serious electric shock.

4. Installing the meters

Install the meters securely in the dashboard where they can be easily read and are not exposed to water splashes. The recommended dashboard thickness is 2~11mm(0.08~0.4 in.). For dashboards thicker than 11mm(0.4 in.), the fitting plate should be cut accordingly. Be sure to tighten the fitting nuts on the fitting plate evenly.

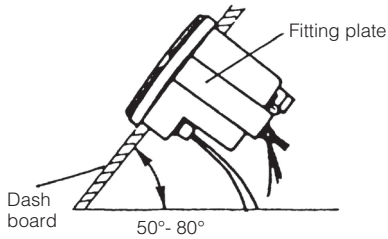

The dashboard inclination should be 50°~80°

Set the tachometer selector knob to "4p".

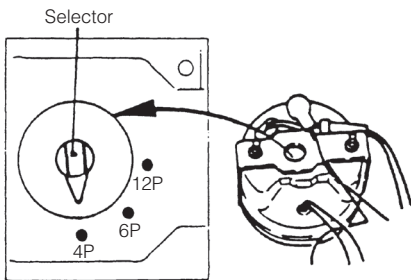

Cut holes with 85mm (3.346 in.) diameter for the tachometer and 52.5mm (2.067 in.) for the trim meter.

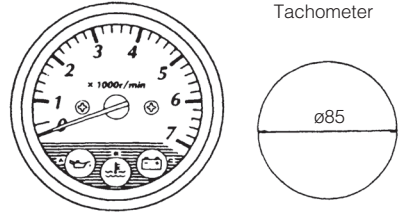

Tachometer

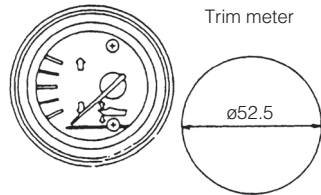

Trim meter

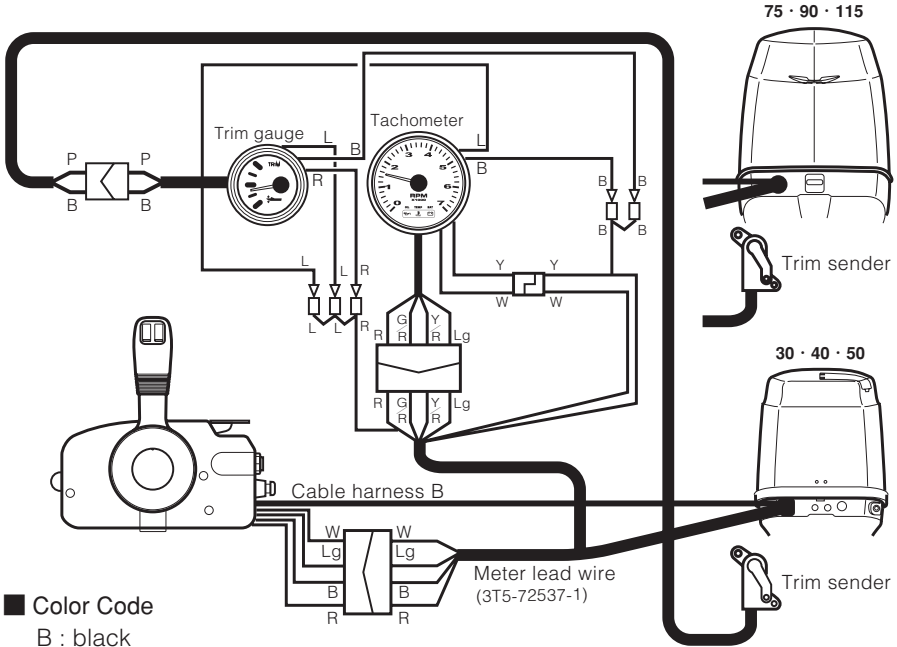

5. Installing the drag link assembly

Incorrect or unstable installation of the Drag Link Assembly can result in accidents while riding the boat or breakage of the hull.

Installation of the Drag Link Assembly by your dealer is highly recommended.

- ① Connect the Drag Link Rod to the tip of the steering cable.
Tighten the rod using self-locking nut, making sure the rod can swing freely.
- ② Connect the other tip of the rod to the steering bracket with a bolt, applying a collar and washer. The bolt head must face downward. Secure with a split pin to the bolt.

Note

Depending on the steering cable manufacturer, spacers (optional) may be required.

Note

Apply grease in required places. (Refer to the illustration below)
Apply grease inside the bracket bolt.

30 · 40 · 50

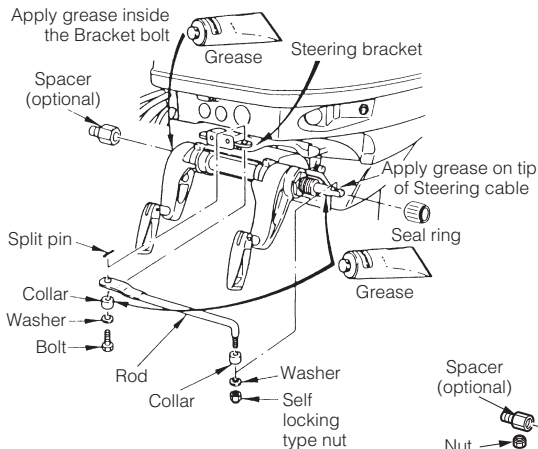

75 · 90 · 115

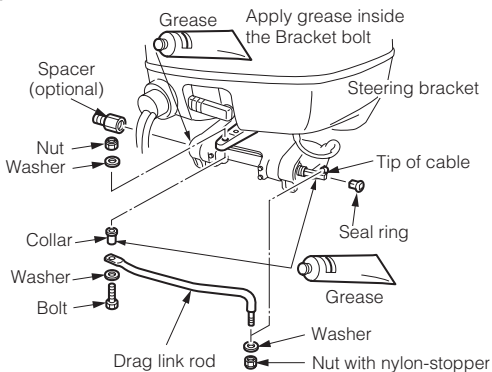

6. Installing the battery

This engine will not start without battery.

Note

Minimum recommended battery more than 0°C : 12V, 100AH (850 Cold Cranking Amps (CCA))
 0°C & below 12V, 120AH (1000 Cold Cranking Amps (CCA))
 Specifications and features of batteries vary among the manufacturers.
 Consult the manufacturer for details.

WARNING

Battery electrolyte contains sulfuric acid and thus is hazardous, causing a burn if it comes in contact with your skin, or poisonous if swallowed.

KEEP BATTERY AND ELECTROLYTE AWAY FROM REACH OF CHILDREN

When handling the battery, be sure to:

- Read all warnings shown on the battery case
- Prevent electrolyte from coming in contact with any part of your body. Contact can cause serious burn or, if attached to eye, loss of sight. Use safety glasses and rubber gloves.

In case battery electrolyte is comes in contact with:

- Skin, flush thoroughly with water.
- Eye, flush thoroughly with water, and then seek immediate receive medical treatment.

In case battery electrolyte is swallowed:

- Seek immediate medical treatment.

WARNING

Battery generates explosive hydrogen gas. Be sure to:

- Charge the battery in a well-ventilated place.
- Place the battery away from any source of fire, sparks and open flames such as burners or welding equipment.
- Do not smoke when handling the battery.
- Do not smoke near the battery when the battery is charging.

CAUTION

- Make sure that the battery cords do not get stuck between the outboard motor and boat when turning, etc.
- The starter motor may fail to operate if the cords are incorrectly connected.
- Be sure to correctly connect the (+) and (-) cords. If not, the charging system will be damaged.
- Do not disconnect the battery cords from battery while the engine is operating, the electrical parts could be damaged.
- Always use a fully charged battery.

CAUTION

Do not use a battery that is not recommended. Use of a battery not recommended can lead to poor performance of, and/or damage to, the electrical system.

4

- ① Keep the battery in the designated battery space of the boat, Secure it tightly and make sure it cannot be reached by water.
- ② Connect the positive(+) cord connector (with red tube) to the positive (+) terminal first. Then connect the negative (-) cord connector to the negative (-) terminal. When disconnecting the battery, always disconnect the negative (-) cord first.

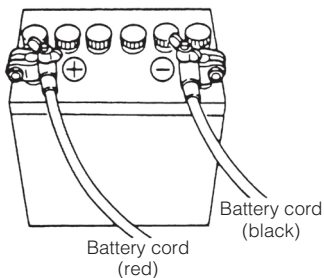

- ③ Recommended battery:
12V, 100Ah/5 hours rate
(CCA=850A)
or 12V, 120Ah/5 hours rate
(CCA=1000A) in cold areas



PRE-OPERATING PREPARATIONS

DANGER

Consult an authorized dealer for details on handling gasoline, if necessary.

Gasoline and its vapors are very flammable and can be explosive.

When carrying a fuel tank containing gasoline:

- Close the air vent screw of fuel tank cap, or gasoline vapor will be emitted through the air vent screw, creating a fire hazard.
- Do not smoke.

When or before refueling:

- Stop the engine, and do not start the engine during refueling.
- Do not smoke.
- Be careful not to overfill fuel tank. Wipe up any spilled gasoline immediately.

When or before cleaning the gasoline tank:

- Dismount fuel tank from the boat.
- Place the fuel tank away from every source of ignition, such as sparks or open flames.
- Do the work outdoors or in a well ventilated area.
- Wipe off gasoline well immediately if spilt.

After cleaning gasoline tank:

- Wipe off gasoline well immediately if spilt.
- If the fuel tank is disassembled for cleaning, reassemble carefully. Imperfect assembly may cause a fuel leak, possibly leading to fire or explosion.
- Dispose aged or contaminated gasoline in accordance with local regulations.

1. Recommended gasoline types

CAUTION

Use of improper gasoline can damage your engine. Engine damage resulting from the use of improper gasoline is considered misuse of the engine, and damage caused thereby will not be covered under the limited warranty.

FUEL RATING

TOHATSU engines will operate satisfactorily when using a major brand of unleaded gasoline meeting the following specifications:

USA and Canada - having a posted pump Octane Rating of 87 (R +M)/2 minimum. Premium gasoline (92 [R+M]/2 Octane) is also acceptable. Do not use leaded gasoline.

Outside USA and Canada - Use unleaded gasoline with declared octane rating of 90 RON or over. Use of premium gasoline of 98 RON is also allowed. Use of name-brand leaded gasoline may be allowed only if unleaded gasoline is not available.

GASOLINES CONTAINING ALCOHOL

The fuel system components on your TOHATSU engine will withstand up to 10% alcohol content in the gasoline. But if the gasoline in your area contains either methanol (methyl alcohol) or ethanol (ethyl alcohol), you should be aware of certain adverse effects that can occur. These adverse effects are more severe with methanol. Increasing the percentage of alcohol in the fuel can also worsen these adverse effects. Some of these adverse effects are caused

because the alcohol in the gasoline can absorb moisture from the air, resulting in a separation of the water/alcohol from the gasoline in the fuel tank.

These may cause increased:

- Corrosion of metal parts
- Deterioration of rubber or plastic parts
- Fuel permeation through rubber fuel lines
- Starting and operating difficulties

! WARNING

Fuel leakage can cause fire or explosion, potentially leading to severe injury or loss of life. Every fuel system part should be checked periodically, and especially after long term storage, for fuel leak, change of hardness of rubber, expansion and/or corrosion of metals. In case any indication of fuel leakage or degradation of fuel part is found, replace relevant part immediately before continuing operation.

If the use of gasoline containing alcohol is inevitable, or presence of alcohol is suspected in the gasoline, it is recommended to add a filter that has water separating capability, and check the fuel system for leaks and mechanical parts for corrosion and abnormal wear more frequently.

And, in case any of such abnormality is found, discontinue the use of such gasoline and contact our dealer immediately.

Damages resulting from the use of gasolines that contain alcohol are not covered under the limited warranty.

Fuel tank capacity :

25 liters (6.6 U.S. gal)---30, 40, 50

Fuel Tank : When using a fixed fuel tank in place of genuine fuel tank, it is recommended to select a one with a

structure facilitating interior cleaning.

! WARNING

Do not fill the fuel tank over capacity. The rise of gasoline temperature may cause gasoline to expand which, if overfilled, may leak through air vent screw when it is open. Leaking gasoline is a dangerous fire hazard.

! CAUTION

When operating a TOHATSU engine on gasoline containing alcohol, storage of gasoline in the fuel tank for long periods should be avoided. Long periods of storage, common to boats, create unique problems. In cars, alcohol blend fuels normally are consumed before they can absorb enough moisture to cause trouble, but boats often sit idle long enough for phase separation to take place. In addition, internal corrosion may take place during storage if alcohol has washed protective oil films from internal components.

2. Low permeation fuel hose requirement

EQUIPPED FOR UNITED STATES AND CANADA MODEL

Required for outboards manufactured for sale, sold, or offered for sale in the United States

- TOHATSU engine has used fuel hoses for The Environmental Protection Agency (EPA) requires from January 1, 2011.

3. EPA pressurized portable fuel tank requirements

EQUIPPED FOR UNITED STATES AND CANADA MODEL

The Environmental Protection Agency (EPA) required portable fuel systems that are produced after January 1, 2011 for use with outboard engines to remain fully sealed (pressurized) up to 34.4 kPa (5.0 psi). These tanks may contain the following:

- An air inlet that opens to allow air to enter as the fuel is drawn out of the tank.
- An air outlet that opens (vents) to the atmosphere if pressure exceeds 34.4 kPa (5.0 psi). A hissing noise may be heard as the tank vents to the atmosphere. This is normal.
- When installing the fuel tank cap, turn the cap to the right until you hear two clicks. This signals that the fuel cap is fully seated. A built-in device prevents overtightening.
- The fuel tank has a manual vent screw which should be closed for transportation and full open for operation and cap removal.

Since sealed fuel tanks are not openly vented, they will expand and contract as the fuel expands and contracts during heating and cooling cycles of the outside air. This is normal.

REMOVING THE FUEL CAP

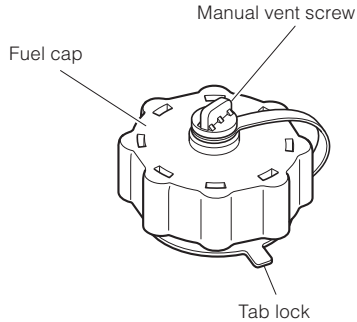

IMPORTANT: Contents may be under pressure. Rotate the fuel cap 1/4 turn to relieve pressure before opening.

- ① Open the manual vent screw on top of the fuel cap completely.
- ② Turn the fuel cap until it contacts the tab lock.
- ③ Press the tab lock and turn to remove cap.

4. Recommended engine oil

Use a genuine engine oil or recommended one. Refer to your Distributor.

Will not recommend use of other two stroke engine oil.

CAUTION

Do not mix different brands of oil. Mixing different brands of oil, or different types of oil even if the brand is the same, may cause gelling, resulting in possible filter screen blockage. This could result in serious engine damage because of impaired lubrication performance.

CAUTION

The engine oil is drained for shipping from the factory. Be sure to fill the engine to the proper level before starting engine. (To properly fill the engine with oil follow the instructions in section 9 of this manual)

Note

Use of engine oils that do not meet these requirements will result in reduced engine life, and other engine problems.

CAUTION

- In the unlikely event that gasoline by mistake is filled into the oil tank, drain the oil tank completely, and consult an authorized service shop for advice.
- Check the amount of oil in the oil tank visually before starting the engine. Running out of oil at sea is a cause for potential disaster.

The required amount of engine oil is automatically supplied from the oil tank, through the oil pump, according to the engine running conditions. Gasoline is fed over a separate feeding line.

■ Replenishing oil in the engine oil tank.

- ① Open the filler lid from the top cowl.
- ② Open the oil tank cap.
- ③ Fill the oil tank with the genuine engine oil.
- ④ After replenishment of the oil tank, be sure to close the oil tank cap tightly.

30 • 40 • 50

Genuine or Recommended
Engine Oil

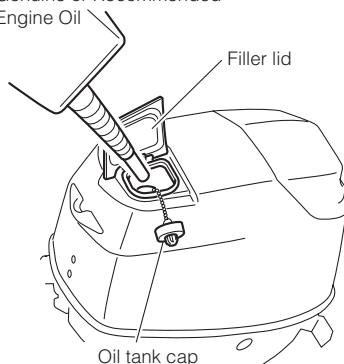

■ Oil pump air vent

Visually check whether there is air in the oil through the vinyl pipe connecting the oil tank with the oil pump. If present, Purge the air as follows:

30, 40, 50

Loosen the air vent screw on the oil pump to purge the air, and tighten it when all air, as seen through the vinyl pipe on the oil pump side, has been purged.

30 • 40 • 50

Air vent screw

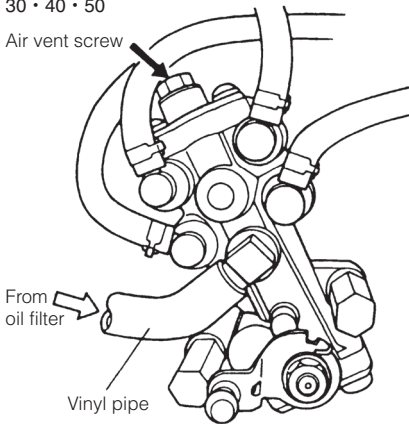

75 • 90 • 115

See page 41 for air removal from the oil lines.

○ Note

Wipe off any spilled oil with a rag, and dispose of it.

5. Break-in

Your new outboard motor and lower unit require break-in for the moving components according to the conditions described in the following time table.

 **CAUTION**

Operating the outboard motor without break-in can shorten service life of the product.

If any abnormality is experienced during the break-in:

- Discontinue the operation immediately.
- Have the dealer check the product and take proper action(s) if necessary.

	1-10min	10min-2hrs	2-3hrs	3-10hrs	After 10hrs
Throttle Position	Idle	Less than 1/2 throttle	Less than 3/4 throttle	3/4 throttle	Full throttle available
Speed		Approx. 3,000 rpm max	Full throttle run allowed for 1 min every 10 min	Approx. 4,000 rpm. Full throttle run allowed for 2 min every 10 min	

 **Note**

Proper break-in allows outboard motor to deliver it full performance for longer service life.

 **DANGER**

Do not operate the outboard motor in closed area or area with no forced ventilation.

Exhaust gas emitted by this outboard motor contains carbon monoxide that will cause death if inhaled continuously. Inhaling the gas initially causes symptoms such as feeling of sickness, drowsiness and headache.

During operation of the outboard motor :

- Keep peripheral area well ventilated.
- Always attempt to stay on the windward side of emission.

6. Warning system

When there is something abnormal with the engine, the warning lamp flashes and/or the buzzer sounds. If a trouble occurs, deal with it as mentioned below.

■ ESG (A device preventing over revolution)

ESG is a device to prevent over revolution of the engine.

If the load to the engine becomes light for some reason, it runs at a higher speed than the usual. In such the case, the buzzer sounds and the ESG is activated not to ignite the spark plug, therefore, the engine speed varies.

Remedy:

Immediately turn the throttle grip or the control lever to the intermediate or lower speed and move the boat to a safe place. Then, shift the control lever or shift lever to the Neutral(N) position and stop the engine.

Engine speed to activate ESG:6,000rpm approx.

○ Note

- If the propeller is damaged such as worn, broken, bent propeller blade(s) or slipping propeller, rubber, replace the propeller.
- If the pitch of the propeller is small and the engine runs at a high speed (rpm), replace the propeller with another proper within the full-throttle speed range.

■ Warning against low oil level

If the engine oil has decreased to the specified quantity or less, the warning system is activated with flashing of the warning lamp and the buzzer that sounds continuative alarms three times at intervals of 2 minutes.

Remarks:

The warning system against low oil level is activated regardless of the shift position of the control lever (shift lever), namely, if it is set at "N", "F" or "R" position.

Engine oil remainder subject to warning		
30 · 40 · 50	75 · 90	115
350ml approx.	1,100ml approx	1,400ml approx.

Tachmeter for EPTO

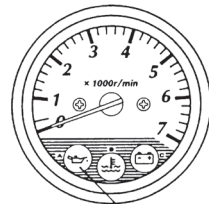

Oil level warning lamp



Switch box for EFO & EFTO

Remedy:

Slow down the engine speed and move the boat to a safe place. Then turn off the main switch and replenish the oil tank with engine oil after the engine completely stops.

After replenishment of oil is complete, start the engine and make sure that the warning lamp in the tachometer is turned off without sounding of the buzzer or the warning lamp in the switch box is turned off without sounding of the buzzer.

■ Cooling water lacking

If the cooling water temperature for the engine exceeds the specific degree during operation, the warning lamp flashes with the buzzer sounding and the engine speed is automatically slowed down.

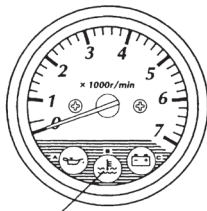

Over heat warning lamp

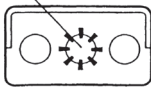

○ Note

This warning is let out according to the sensing result of the cooling water only; without regard to sensing conditions of combustion, lubrication, etc.

Remedy:

Move the boat to a safe place as soon as possible, and turn the throttle grip or control lever to the low speed position. Then, shift the shift lever or control lever to the Neutral(N) position and stop the engine after making sure that cooling water is drained out of the cooling water check port.

If dust, vinyl, etc. are adhering to the gear case, remove them.

Sensing temperature of sensor	Controlled engine speed	Remedy ※
high-Temperature (Low speed ESG)	2,800 to 3,200 rpm	①
Unusual-high-Temperature (forced Idle)	700 to 900 rpm	②

① Slow down to idling speed

② Stop the engine

※ This controlled engine speed will not be canceled unless the following operation ① and ② is done although the cooling water get back to normal temperature.

⚠ CAUTION

If the buzzer sounds frequently after restarting the engine, please contact your dealer.

■ Battery voltage too low

If the battery voltage drops to 10 V or lower, the warning lamp flashes.

And also if the voltage is too high, all of the three warning lamps flash.

If the battery is defective or the battery cable is poorly connected, the warning lamp flashes and the engine speed is automatically slowed down to 2,800 to 3,200 rpm. If the defect is serious, the engine will stop.

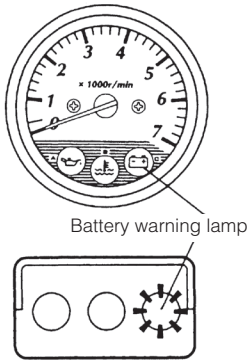

Battery warning lamp

Remedy:

- Check the battery cable connection. If there is a poor connection, reconnect it tightly.
- Charge the battery.
- Replace the battery with a new one.

■ Engine trouble

In case of an engine trouble, all the three warning lamps flashes at the same time.

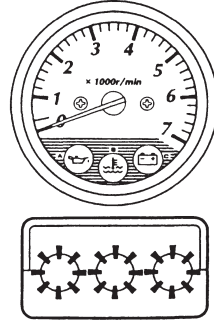

○ Note

This warning system has three kind indications with cause of engine trouble as below.

- ① The warning lamp flash
- ② The engine speed control 2,800 ~3,200 rpm and the warning lamp flash
- ③ The engine speed control 700~900 rpm and the warning lamp flash.

Remedy:

Consult your dealer about the trouble, because the engine needs inspection and repair service by an authorized serviceman in this case.

ENGINE OPERATION

1. Starting

! WARNING

In case engine starts in gear, do not start cruising. Stop engine immediately and consult an authorized dealer.

Note

The engine will not start unless the switch lock has been properly connected into the emergency stop switch.

! WARNING

Do not operate the engine with gear case out of water. Severe personal injury, or engine damage will result.

! CAUTION

Never fill up portable fuel tanks on board to avoid fire or explosion resulting from spilled gasoline. If gasoline is ever spilled on board, wipe it up thoroughly. Fuel tanks must always be filled up on land.

Preparations

Except for USA and Canada model (regular tank)

- ① Full open the air vent screw on the tank cap.

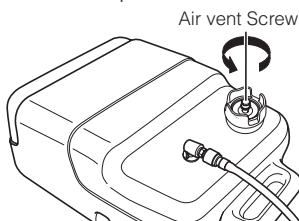

For USA and Canada model (EPA approved tank)

- ① Full open the air vent screw on the tank cap and turn the tank cap until it contacts the tab lock. Close the tank cap after completely releasing pressure.

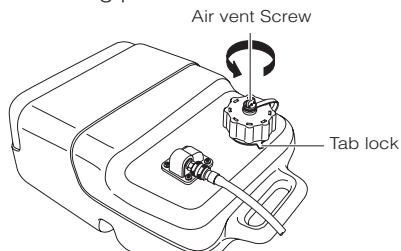

- ② For the 30, 40 and 50 models, insert the fuel connector into the connector in the engine side.

30 · 40 · 50

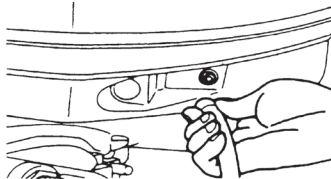

For the 75, 90 and 115 model, remove the cap from the fuel hose nipple and then connect the hose coming from the fuel tank.

After connection, be sure to fasten the hose tightly with a hose band or the like.

75 · 90 · 115

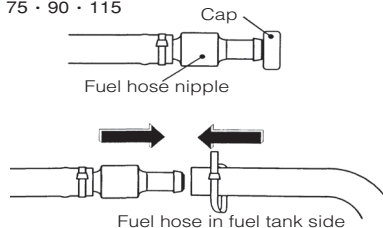

- ③ Install a lock in the stop switch.

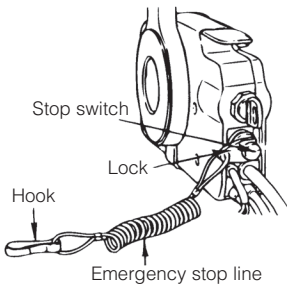
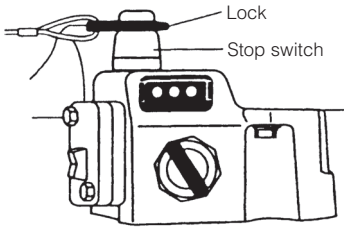

- ④ Feed fuel to the engine by squeezing the primer bulb until it is firm.

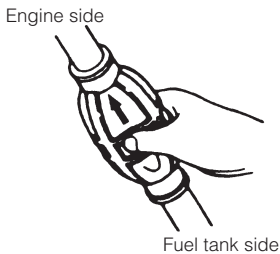

Forced fuel feeding

When the engine is new, stops because of emptying fuel tank or have been left without operation for a long time, or just after the engine is overhauled, be sure to execute the following operation for feeding the engine with fuel forcedly before starting the engine.

- Repeat to squeeze the primer bulb until it becomes firm.
- Set the main switch to "ON" position and hold it turned on for 3 seconds. – To actuate the FFP (Fuel Feed Pump).
- Turn off the main switch and again squeeze the primer bulb repeatedly until it becomes firm.
- Repeat the above steps b and c until the primer bulb remains as it is firm.

Forced engine oil feeding

When the engine is new or have been left without operation for a long time, or just after the engine is overhauled, be sure to execute the following operation for forcedly feeding the engine oil to the oil line before starting the engine.

■ 30, 40, 50 type

- Disconnect the link rod by turning the rod snap interlocking with the oil pump as shown in the figure.
- Make sure that the oil pump control lever is set at open side position.
- Idle the engine for more than 30 minutes.
- Reset the link rod to the advancer arm.

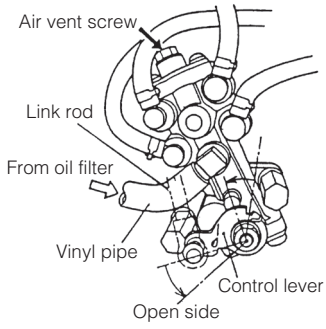
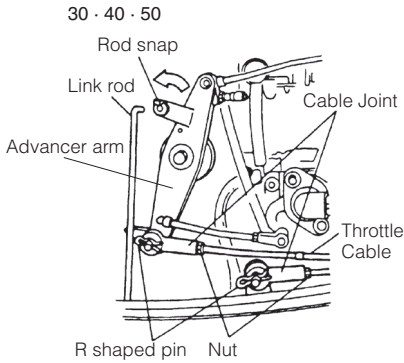

■ **75·90·115 type (Electric Oil Pump)**
 Check to see by eyes if the oil line from the oil tank to the cylinder block (① to ⑪ in the 75, 90, 115 model) gets air inside or not. If there is air inside the oil line, remove it as follows.

◎ Oil tank-Filter (①)

- a. Fill the oil tank up with the specified oil.
- b. Remove the pipe of the filter inlet side at the part ①
- c. Since the oil drains out with air, wait until air is completely discharged from the pipe. After checking for no air in the oil line, reconnect the pipe as it was and attach the clip to secure pipe connection.

◎ Filter-Oil Pump-Cylinder Block (75 · 90 · 115 : ② - ⑪)

- a. Turn on the key switch.
- b. Within 1 second after the buzzer stops sounding, remove the stop switch lock.
- c. Within 2 seconds after removing the stop switch lock, quickly repeat pulling and pushing back the stop switch knob 2 times.
- d. The buzzer sounds 3 times and the oil pump is actuated for about 1 minute for pressure feed or oil.
- e. When air is completely removed from the oil line, turn off the key switch.

75 · 90 · 115

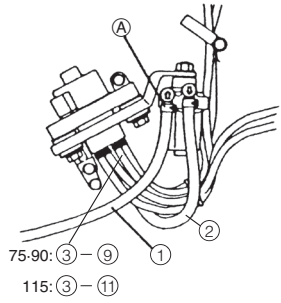
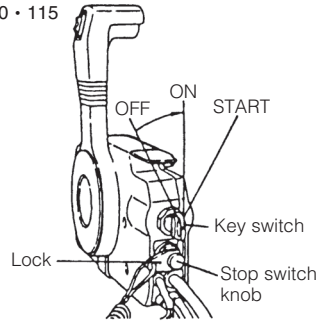

Starting

■ EFO, EFTO type

- ① Set the shift lever to Neutral

⚠ CAUTION

If the engine starts in gear, do not use it. Contact an authorized dealer.

○ Note

Start-in-gear protection prevents engine from starting at other than neutral shift. In-gear starting of engine will move the boat immediately, potentially leading to falling down or causing passenger(s) to be thrown overboard due to inertial force.

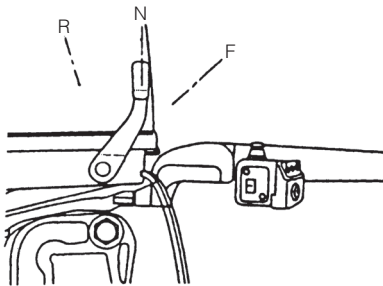

- ② Turn the throttle grip so that the indicator line meets the "START" mark (completely closed).

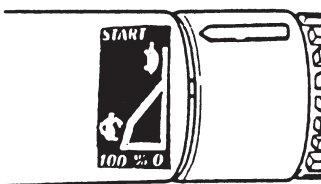

○ Note

Turn the handle grip to the "START" (fully closed), before turning the main switch key to "ON".
The wrong operation i.e. turn the main switch key to "ON" on the condition that the handle grip is opened will be memorized by ECU (engine control unit).
If this wrong operation has done repeatedly, it will have a possibility that the three warning lamps flash. In this case, turn the handle grip to "START" (fully closed) and start the next operation after returning the main switch key to "OFF".

- ③ Turn the main switch key to "ON", and wait a few seconds until the sound of the warning buzzer stops. And then continue turning the key clockwise to start the engine.

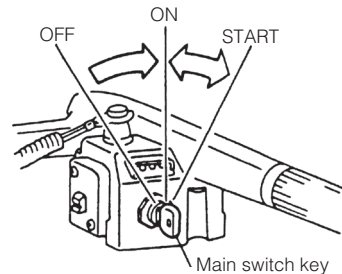

○ Note

If the main switch key is pressed for 1(one) second during idling or trolling operation, the buzzer sounds and engine revolution changes.
Each time the main switch key is pressed in the above manner, engine speed changes as follows.
700 → 800 → 900 → 800 → 700 → 800 → 900rpm →

- ④ Release the main switch key as soon as the engine starts. The key will return to the "ON" position automatically.

⚠ WARNING

Do not operate the engine with gear case out of water. Severe personal injury, or engine damage will result.

⚠ CAUTION

Do not keep turning starter motor for over 5 seconds, or the battery may be consumed, potentially making the engine starting impossible and/or damaging the starter. If cranking over 5 seconds fails to start engine, return main switch to "ON", and crank engine again after 10 seconds or more.

6

■ EPTO type

- ① Insert the key into the remote control box.
- ② Set the Remote Control lever to Neutral (N).

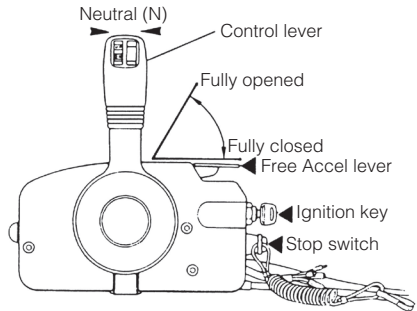

○ Note

Turn the free accel lever to the fully closed position, before turning the main switch key to "ON". The wrong operation i.e. turn the main switch key to "ON" on the condition that the lever is opened will be memorized by ECU (engine control unit). If this wrong operation has done repeatedly, it will have a possibility that the three warning lamps flash. In this case, turn the lever to the fully closed position and start the next operation after returning the main switch key to "OFF".

○ Note

The free accel lever can not be raised when the control lever shift is in Forward or Reverse.

- ③ Turn the main switch key to "ON", and wait a few seconds until the sound of the warning buzzer stops.

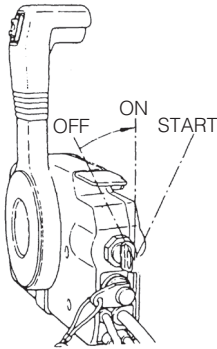

- ④ Continue turning the key clockwise to start the engine. When the engine starts, release the key and allow it to return to "ON".

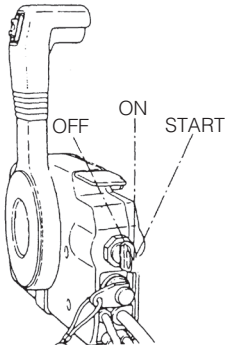

Note

If the main switch key is pressed for 1(one) second during idling or trolling operation, the buzzer sounds and engine revolution changes. Each time the main switch key is pressed in the above manner, engine speed changes as follows.
700 → 800 → 900 → 800 → 700 → 800 → 900rpm →

WARNING

Do not operate the engine with gear case out of water. Severe personal injury, or engine damage will result.

CAUTION

Do not keep turning starter motor for over 5 seconds, or the battery may be consumed, potentially making the engine starting impossible and/or damaging the starter. If cranking over 5 seconds fails to start engine, return main switch to "ON", and crank engine again after 10 seconds or more.

If the starter motor fails to operate

2. Warming up the engine

Before driving the boat, let the engine run at low speed to let it warm and allow the oil to circulate through the engine. If the engine is not warmed up beforehand, the engine life will shorten greatly.

This outboard engine automatically controls warm-up operation, namely, it runs at a speed slightly higher than idling just after it is started, and it reverts to the normal running at a preset speed after warm-up is complete.

During the warm-up operation, confirm that cooling water is discharged from the check port and idle port.

! CAUTION

If cooling water is not discharged and engine operation is continued, the engine will overheat and damage occur.

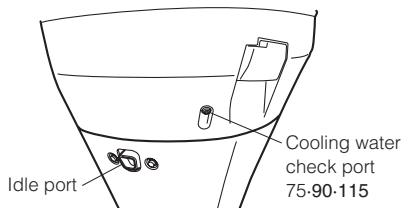
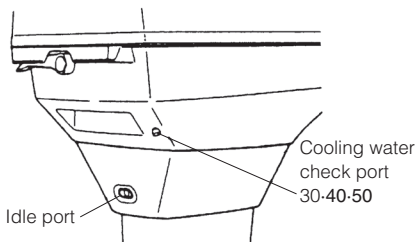

! CAUTION

Be sure to stop engine immediately if cooling water check port is not discharging water, and check if cooling water intake is blocked. Operating engine could lead to overheating potentially leading to engine damage. Consult an authorized dealer if the cause cannot be found.

■ Engine speed

Proper idle speed after warm-up operation.

Clutch in (In gear)	Clutch off (Out of gear)
700 rpm	700 rpm
700/800/900 rpm	700/800/900 rpm

! CAUTION

Do not shift to "F" or "R" until turning into proper idle speed.

Do not exceed the full-throttle engine speed.

Wide-open throttle rpm range
5,150~5,850rpm

3. Forward and reverse

WARNING

Before shifting into forward or reverse, make sure that boat is properly moored and outboard motor can be steered fully to the right and left. Make sure that no swimmer(s) is ahead or astern of the boat.

WARNING

- Attach other end of emergency stop switch tether to the operator's clothing or arm and keep it attached during cruising.
- Do not attach the tether to a part of clothing that can be torn easily when pulled.
- Arrange the tether so that will not be caught by any object when pulled.
- Be careful not to pull the tether accidentally during cruising. Unintentional stop of engine can cause loss of control of outboard motor. Rapid loss of engine power can lead to falling down or causing passenger(s) to be thrown over board.

WARNING

Be sure to connect the emergency tethered stop hook to your waist or clothing.
The engine will shut down when the switch lock becomes disconnected from the engine.

Note

Do not increase engine speed unnecessarily in reverse.

■ EFO, EFTO type

Turn the throttle grip toward "SLOW" and move the Shift Lever quickly to Forward or Reverse when the engine speed has reached the lowest rpm.

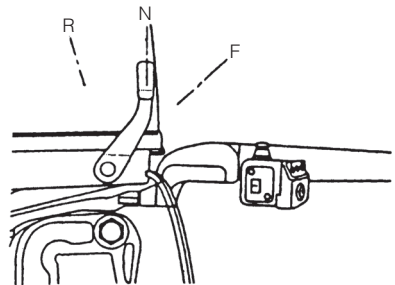
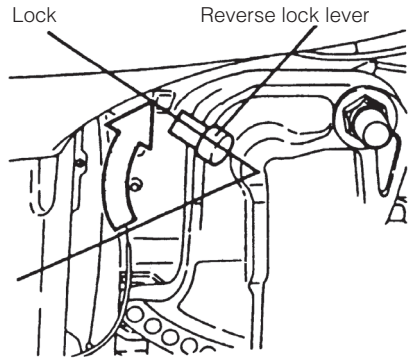

WARNING

Severe damage, and personal injury, may occur if shifting at high engine speed.
Engine must be in the slow idle position before shifting is attempted.

⚠ WARNING

Before shifting, make sure that no swimmer(s) or obstacle(s) is ahead or astern of the boat.

⚠ CAUTION

- Before moving the Shift Lever to Reverse, make sure the Reverse Lock is engaged (in up position).--- EFO model only.

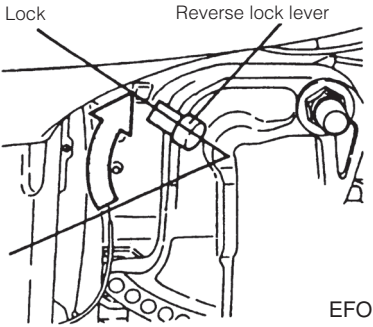

- Do not increase the engine speed unnecessarily while reversing.
- The Shift Lever cannot be turned from Neutral to Reverse unless the throttle grip has been turned fully toward "SLOW".

■ EPTO type

While pressing the lock button on the Remote Control Lever upward, swiftly move the Lever to Forward (F) or Reverse (R) to the engaging point (approx.32° forward or backward from Neutral). If the lever is moved further forward or backward, the throttle will open.

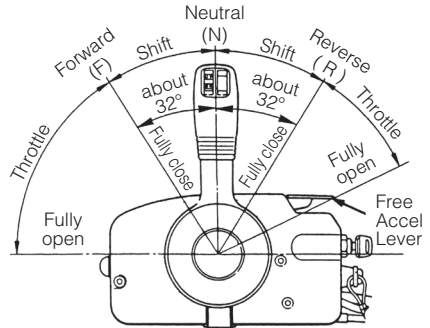
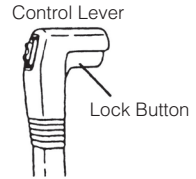

○ Note

The remote control lever becomes inoperative unless the free accel lever is in the fully closed position.

⚠ CAUTION

- The engine must be at idling speed when the Shift Lever is moved from Forward to Reverse.
- Do not increase the engine speed unnecessarily while reversing.

⚠ CAUTION

Be sure to warm up engine well before starting cruise. Operating cold engine can give damage to it.

○ Note

Idle speed may be higher during warming up of engine. If shifted to Forward or reverse during warming up, it may be difficult to shift back to neutral. In such case, stop engine, shift to neutral, and restart engine to warm up.

○ Note

Frequent shifting to forward or reverse can accelerate wear or degradation of parts. In such case, replace gear oil earlier than the period specified.

4. Shallow water running**⚠ WARNING**

During shallow water operation, be careful not to place your hand between the swivel bracket and the stern bracket. Be sure to tilt the outboard down slowly.

○ Note

Slow down to trolling speed, and shift into neutral before setting outboard motor to shallow water drive position.

⚠ WARNING

- Run at lowest possible speed during cruising using shallow water drive.
- Tilt lock is disabled when in shallow water drive position.
- When driving shallow water, be careful not to strike outboard motor against sea bottom, or propeller may be pushed out of water, resulting in loss of control.

⚠ CAUTION

While in shallow water drive position, do not operate the outboard in reverse. Operate the outboard at slow speed and keep the cooling water intake submerged.

■ EFO type

- ① Set the Reverse Lock Lever provided on the starboard side to "Release" by turning it downward.

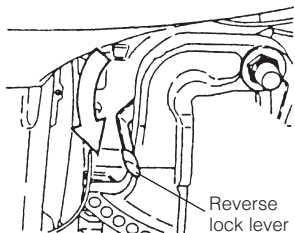

- ② Tilt the engine up approx. 45° and lower it. The engine will now be set to the shallow water setting.

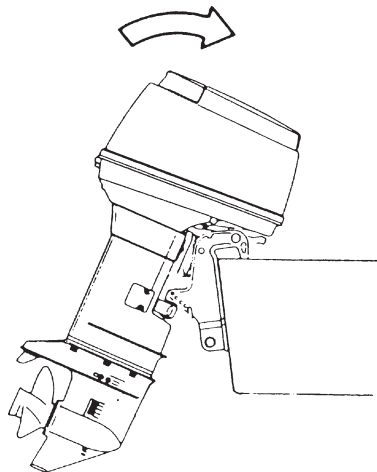

- ③ Releasing the shallow water setting
 - a. Turn the Reverse Lock Lever upward to set them in "LOCK" position.
 - b. Tilt up the engine slightly and then let it go down. The shallow water setting is then released.
 - c. The engine is released from shallow water setting, and locked at normal running position.

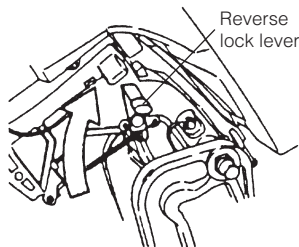

■ EFTO, EPTO type

Tilt up the engine using the Power Trim & Tilt system.

5. Stopping the engine

WARNING

- Do not shift into Reverse during planning, or control will be lost leading to serious personal injury, boat may swamp, and/or hull may be damaged.
- Do not shift into Reverse during cruising, or control may be lost, falling down or causing passenger(s) to be thrown overboard. Leading to serious personal injury, and steering system and/or shifting mechanism may be damaged.

CAUTION

Never stop the engine immediately after a full throttle run. Keep it running for two or three minutes at idling speed (Shift Lever set to Neutral) to allow it to cool down.

■ EFO, EFTO type

- ① Reduce the engine speed to idling rpm.
- ② Turn the Main Switch to "OFF". The engine will then stop.

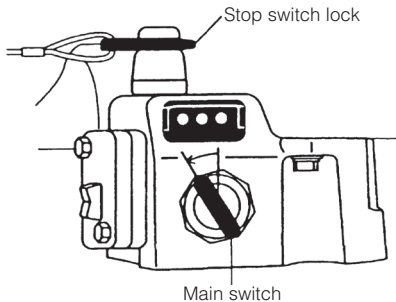

■ EPTO type

- ① Move the Remote Control lever to Neutral (N) and let the engine idle for 2-3 minutes to allow it to cool down.

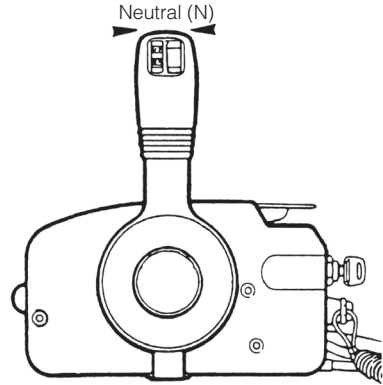

- ② Turn the main switch key counter-clockwise. The engine will stop.

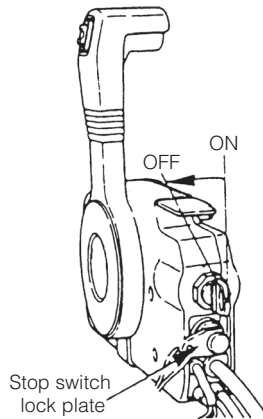

■ EFO, EFTO, EPTO type

○ Notes

- After stopping the engine, close the air vent screw on the tank cap.
- Disconnect the fuel connector of the engine or the fuel tank.
- Disconnect the cables from the battery if the engine will not be used for an extended period of time.

③ Disconnect the fuel connector from the engine.

30 · 40 · 50

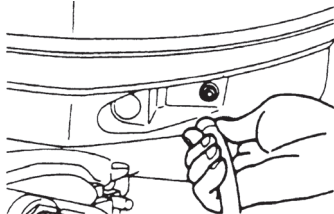

⚠ CAUTION

Never fill up portable fuel tanks on board to avoid fire or explosion resulting from spilled gasoline. If gasoline is ever spilled on board, wipe it up thoroughly. Fuel tanks must always be filled up on land.

④ Close the air vent screw on the fuel tank cap.

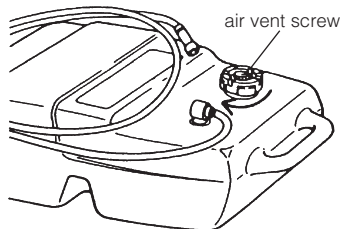

6. Trim angle

The following instructions explain how to set the best trim angle of the boat.

EFO type

The trim angle is adjusted by setting the thrust rod in the correct thrust rod hole.

■ Proper trim angle

The trim angle is optimum when the boat is parallel to the water surface while running.

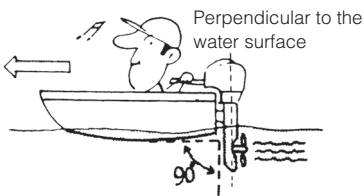

■ Improper trim angle (bow rises too high)

If the trim angle is excessive, the bow will rise out of the water and the speed will decrease.

Furthermore, the bow may sway or the bottom may slam the water while cruising.

In this case, decrease the trim angle by setting the thrust rod in a lower hole.

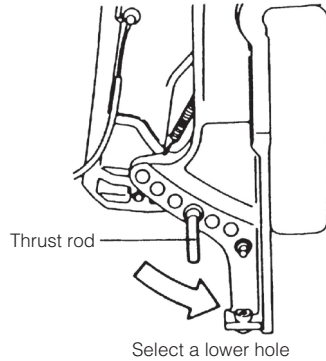

■ Improper Trim Angle (bow dips into the water)

If the trim angle is too small, the bow will dip into water, the speed will decrease, and water may enter the boat.

In this case, the trim angle should be increased by setting the thrust rod in a higher hole.

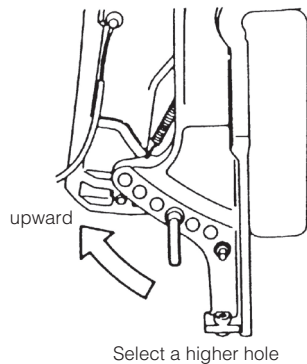

⚠ WARNING

- Do not put hand or finger in between outboard motor body and clamp bracket when adjusting trim angle to prevent injury in case the outboard motor body falls.
- Unsuitable trim position can cause loss of control of boat.
When testing a trim position, run boat slow initially to see if it can be controlled safely.

⚠ WARNING

Excessive trim up or down may lead to unstable boat operation, potentially causing the steering difficulty that leads to accident during cruising.

- Do not cruise at high speed if improper trim position is suspected. Stop the boat and readjust trim angle before continuing cruise.
- For outboard motor model with PTT switch on the bottom cowl, do not operate the switch during cruising, or control of boat may be lost.

EFTO, EPTO type

The Provided Power Trim & Tilt can be adjusted to set the desired trim angle of the outboard motor in relation to the transom shape, planing speeds and load. It is imperative that the trim angle is adjusted correctly. Incorrect adjustment will cause the boat to sway, deteriorate engine performance and may cause unsafe steering conditions.

⚠ CAUTION

The Power Trim & Tilt can be set to any trim angle, however, avoid cruising with the outboard motor tilted in the tilt range. Operating the boat in this manner, the outboard motor may ingest air into the water cooling system, resulting in engine overheating.

■ How to use the trim meter

When the trim angle is set as desired, take a reading off the trim meter, and record it for future reference.

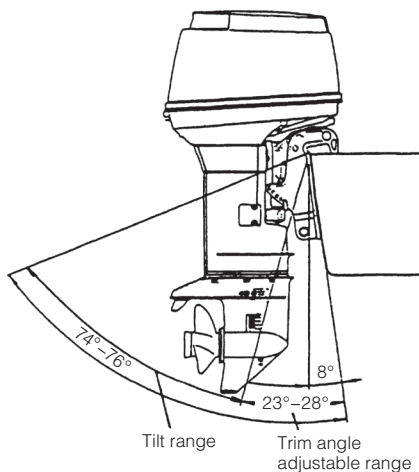

■ Improper Trim Angle (bow rises too high)

If the trim angle is excessive, the bow will rise out of the water and the speed will decrease.

Furthermore, the bow may sway or the bottom may slam the water while cruising.

In this case, decrease the trim angle by pressing the switch on the Remote control level to "DN".

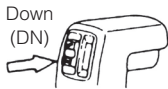

■ Improper Trim Angle (bow dips into the water)

If the trim angle is too small, the bow will dip into the water, the speed will decrease, and water may enter the boat. In this case, the trim angle should be increased by pressing the switch on the remote control lever to "UP".



■ Proper Trim Angle

The trim angle is optimum when the boat is parallel to the water surface while running.

WARNING

- Do not put hand or finger in between outboard motor body and clamp bracket when adjusting trim angle to prevent the body parts from being caught in case the outboard motor body falls.
- Unsuitable trim position can cause loss of control of boat. When testing a trim position, run boat slow initially to see if it can be controlled safely.

WARNING

Excessive trim up or down may lead to unstable boat operation, potentially causing the steering difficulty that leads to accident during cruising.

- Do not cruise at high speed if improper trim position is suspected. Stop the boat and readjust trim angle before continuing cruise.
- For outboard motor model with PTT switch on the bottom cowl, do not operate the switch during cruising, or control of boat may be lost.

7. Mooring with the engine tilted up

When the engine has been stopped and it will not be used for a long time or when mooring in shallow water, tilt the engine up to prevent damage to the propeller and gear case.

EFO type

- ① Disconnect the fuel connector from the engine.

30 · 40 · 50

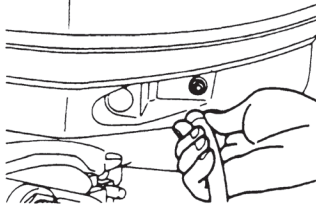

- ② Set the Reverse Lock Lever on the starboard side to "RELEASE" by turning it downward.

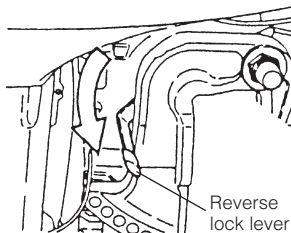

- ③ Tilt the engine up entirely. The tilt will lock in the raised position.

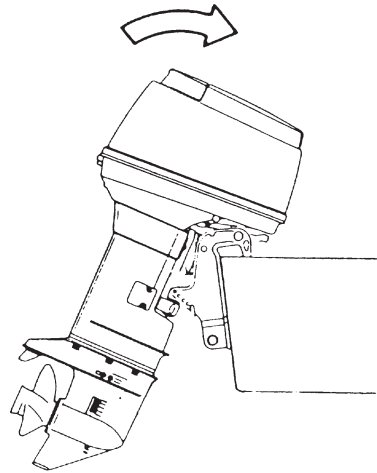

⚠ WARNING

- Do not put hand or finger in between outboard motor body and clamp bracket when adjusting trim angle to prevent the body parts from being caught in case the outboard motor body falls.
- When tilting up outboard motor with fuel joint for over a few minutes, be sure to disconnect fuel hose or close fuel cock, or fuel may leak, potentially catching fire.

⚠ CAUTION

Do not tilt up outboard motor during operation, or engine may be damaged from overheating because of no feed of cooling water.

- ④ To tilt the engine down, Turn the Reverse Lock Lever upward (toward "LOCK"). Tilt the engine up slightly and then let it go down. (The Reverse Lock will be set automatically.)

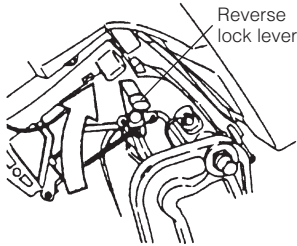

EFTO, EPTO type

- ① Disconnect the fuel connector from the engine.

30 · 40 · 50

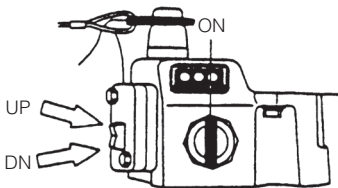
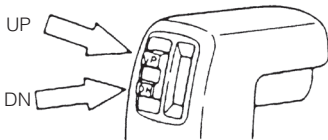
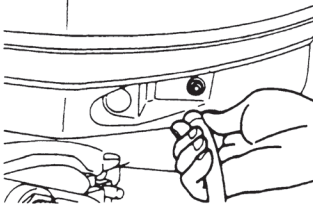

- ② Operate the Power Trim & Tilt switch and tilt and engine up.

The engine can also be tilted up using the switch provided under the Lower Engine Cover.

30 · 40 · 50 · 75 · 90 · 115

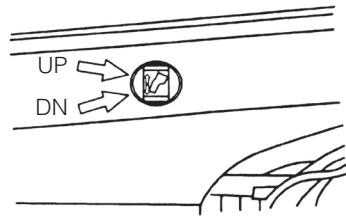

It is possible to tilt up or down in spite of main switch "ON" or "OFF".

- ③ Lock the tilt with the Tilt stopper after the engine has been tilted up.

30 · 40 · 50

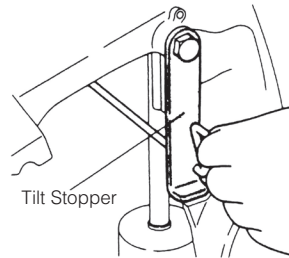

75 · 90 · 115

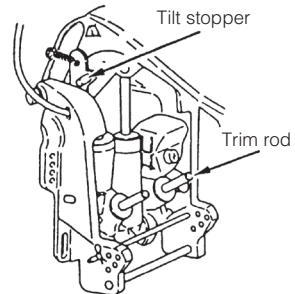

④ Manual tilting

If the battery is dead, and the Power Trim & Tilt Switch thus inoperative, turn the manual valve a few turns in the Manual direction. This will allow manual tilting of the engine.

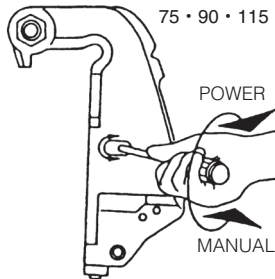
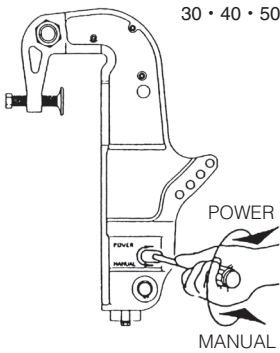

! WARNING

Do not tilt up or down outboard motor when swimmer(s) or passenger is near to prevent them from being caught between outboard motor body and clamp bracket in case the outboard motor body falls.

! WARNING

When tilting up outboard motor with fuel joint for over a few minutes, be sure to disconnect fuel hose or close fuel cock, or fuel may leak, potentially catching fire.

! CAUTION

Do not tilt up outboard motor while engine operates, or no cooling water may be fed, leading to engine seizure due to overheating.

○ Note

For U.S.A. market only

High altitude :

When engine operates at high altitude engine may need to have a high altitude kit installed. Otherwise, operating the engine at high altitude may increase its emissions and decrease fuel efficiency and performance. Please see "LIMITED WARRANTY INFORMATION" for more detail.

REMOVING AND CARRYING THE OUTBOARD MOTOR

1. Removing the outboard motor

- ① Stop the engine.
- ② Disconnect the fuel connector, the remote control cables, the battery cords, bracket fixing bolts and nuts etc.
- ③ Remove the outboard motor from the hull and completely drain the water from the gear case.

CAUTION

Do not carry the outboard motor immediately after stopping engine when they are so hot that they burn hands if touched.

2. Carrying the outboard motor

Be sure to keep the engine vertical whenever you carry the outboard motor.

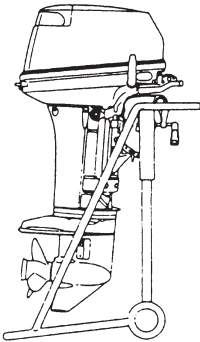

WARNING

- Close air vent screw of fuel tank before carrying or storing outboard motor and fuel tank, or fuel may leak, potentially catching fire.
- Do not give a shock to an outboard motor during transportation. It becomes a cause of breakage.

WARNING

Please disconnect fuel connector except when operating engine. Fuel leakage is a fire or explosion hazard, which can cause serious injury or death.

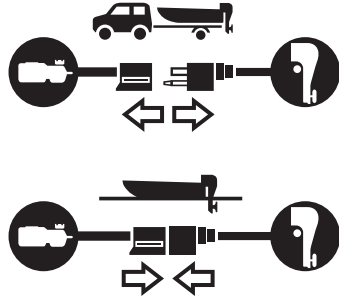

■ EFTO, EPTO type

When carrying or putting the engine up for storage, make sure the side with the electric motor of the Power Trim and Tilt is down otherwise air will enter the pump system for the Power Trim and Tilt operation.

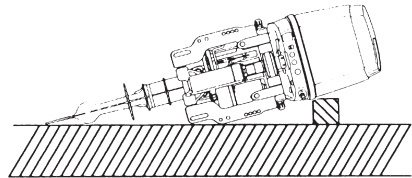

■ EFO type

Lay the engine with the shift lever up.

3. Storing the outboard motor

Keep the motor in a vertical position when you store it.

Note

If you store the motor in a horizontal position, lay the motor as shown in figure of last page.

EFO type

WARNING

When taking the motor from package or removing the motor from the boat, never release the lock lever. If the lock lever is released, it will be very easy the clamp bracket to spring up to the tilting direction because it is not fixed.

- * Tie the clamp bracket to the outboard with a rope.
- * Pay attention to the tilting direction so as not to be injured by the springing clamp bracket.

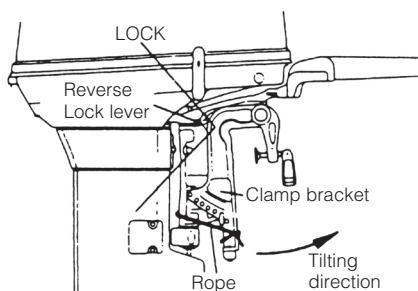

WARNING

Do not go under outboard motor tilted up even if it is supported by support bar, or accidental fall of outboard motor could lead to severe personal injury.

WARNING

Close air vent screw of fuel tank and fuel cock before carrying or storing outboard motor and fuel tank, or fuel may leak, potentially catching fire.

TRAILERING

CAUTION

When trailering the outboard motor should be in a vertical (normal running) position, fully down. Trailering in the tilted position may cause damage to the outboard motor, boat, etc.

If trailering with outboard motor fully down is not available (the gear case skeg is too close to the road in a vertical position), fix the outboard motor securely using a device (like a transom saver bar) in the tilted position.

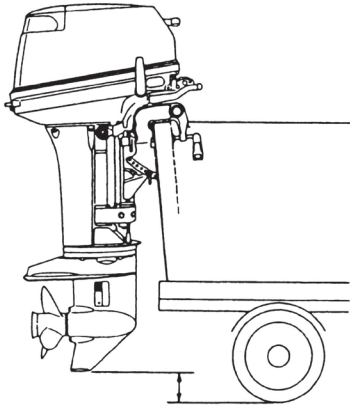

CAUTION

The tilt support device supplied on your outboard motor is not intended for trailering. It is intended to support the outboard motor while the boat is docked, beached, etc.

ADJUSTMENT

1. Remote control lever load

■ EPTO type only

(Throttle friction adjustment screw)

To adjust the load of the remote control lever, turn the throttle friction adjustment screw on the front of the remote control Box. Turn clockwise to increase the load and counter-clockwise to decrease it.

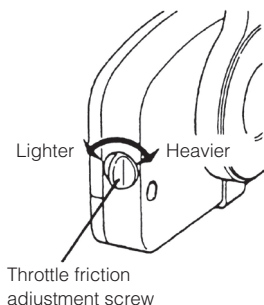

2. Trim tab adjustment

If straight-line cruising can not be achieved, adjust the trim tab located under the anti-ventilation plate.

- ◎ If the boat veers toward the right, direct the trim tab towards A.
- ◎ If the boat veers toward the left, direct the trim tab towards B.

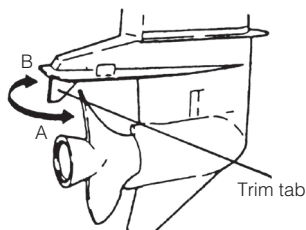

○ Notes

- The trim tab also acts as an anode to prevent electrolytic corrosion. Therefore do not paint or grease this part.
- After adjustment securely tighten the trim tab fixing bolt.
- Check for looseness of the bolt and the trim tab at regular intervals. Due to corrosion, the trim tab will wear down over time.

⚠ WARNING

- Inappropriate adjustment of trim tab could cause steering difficulty. After installing or readjusting trim tab, check if steering load is even.
- Tighten trim tab bolt to specified torque.

⚠ WARNING

- Be sure that outboard motor is secured to transom or service stand, or accidental drop or fall of outboard motor could lead to severe personal injury.
- Be sure to lock outboard motor if it is tilted up, or accidental fall of outboard motor could lead to severe personal injury.
- Do not go under outboard motor tilted up and locked, or accidental fall of outboard motor could lead to severe personal injury.

3. Steering load adjustment

■ 30, 40, 50 type

Steering load can be adjusted by turning the steering adjust bolt on the Swivel Bracket.

Turn clockwise to increase load

Turn counter-clockwise to decrease the load

EFO

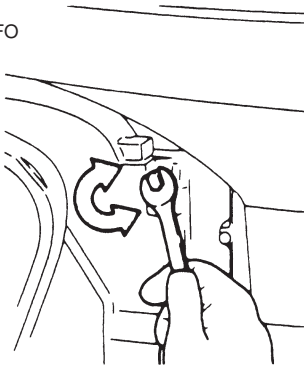

EFTO, EPTO

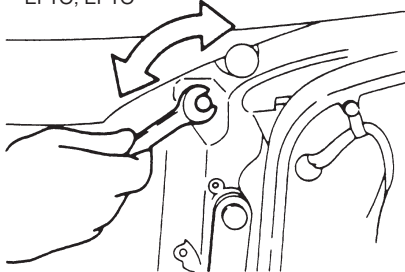

4. Throttle grip turning load adjustment

■ EFO, EFTO type

Turn the friction adjustment screw on the steering handle to adjust the turning load of the throttle grip.

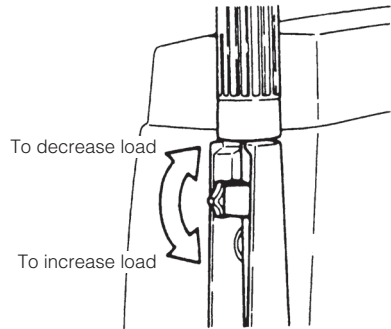

! WARNING

Do not increase throttle friction excessively, or heavy movement of throttle grip or remote control lever movement could cause loss of throttle control potentially leading to accident.

INSPECTION AND MAINTENANCE

Care of your outboard motor

To keep your outboard motor in the best operating condition, it is very important that you perform daily and periodic maintenance as suggested in the maintenance schedules that follow.

CAUTION

- Your personal safety and that of your passengers depends on how well you maintain your outboard motor. Carefully observe all of the inspection and maintenance procedures described in this section.
- The maintenance intervals shown in the checklist apply to an outboard motor in normal use. If you use your outboard motor under severe conditions such as frequent full-throttle operation, frequent operation in brackish water, or for commercial use, maintenance should be performed at shorter intervals. If in doubt, consult your dealer for advice.
- We strongly recommend that you use only genuine replacement parts on your outboard motor. Damage to your outboard motor arising from the use of other than genuine parts is not covered under the warranty.

EPA Emissions Regulations

EPA (United States Environmental Protection Agency) has emission regulations regulating air pollution from new outboard motors. All new outboard motors manufactured by us are certified to EPA as conforming to the requirements of the regulations. This certification depends upon factory standards. Therefore, factory specifications must be followed when servicing emission related controls, or making adjustments. **Maintenance, replacement, or repair of the emission control devices and systems may be performed by any marine SI (Spark Ignition) engine repair establishment or individual.**

1. Daily inspection

Perform the following checks and inspection before and after use.



WARNING

Do not use outboard motor on which any abnormality is found during pre-operation check, or it could go into trouble during cruising potentially leading to accident.

Item	Points to Check	Action
Fuel System	<ul style="list-style-type: none"> ● Check the amount of fuel in the tank. ● Check for dust or water in the fuel filter. ● Check rubber pipes for oil leakage. ● Fuel 	Replenish Clean Replace
Fuel Tank Cap	<ul style="list-style-type: none"> ● Check for crack, leakage, damage in the fuel tank cap. ● Check for crack, damage in the gasket and teather. ● Check for leakage at full close. ● Check for ratchet performance. 	Replace Replace Replace Replace
Lubrication System	<ul style="list-style-type: none"> ● Check the amount of engine oil in the oil tank. ● Check for dust or water in the oil filters. 	Replenish Clean
Electrical Equipment	<ul style="list-style-type: none"> ● Check the spark plugs for dirt, wear and carbon built-up. Spark plugs (30-40-50-75-90) NGK IZFR6Q (0.8mm gap) (0.0315 in) Spark plugs (115) NGK IZFR5J (0.8mm gap) (0.0315 in) ● Check if the main switch functions normalty. ● Check if the battery electrolyte level and specific gravity are normal ● Check for loose connections on battery terminal. ● Check if the stop switch functions normally and make sure the lock plate is present. ● Check cords for loose connections and damage. 	Clean or replace Remedy or replace Replenish or recharge Retighten Remedy or replace Correct or replace
Throttle System	<ul style="list-style-type: none"> ● Check if the magneto works normally when turning the throttle grip, and also check links for looseness. 	Correct
Clutch and Propeller System	<ul style="list-style-type: none"> ● Check if the clutch engages correctly when operating the Remote Control. (or Shift lever) ● Check the propeller for bent or damaged blades. ● Check if the propeller nut is tightened and the split pin is present. 	Adjust Replace
Installation of Motor	<ul style="list-style-type: none"> ● Check all the motor installation bolts with the boat. ● Check the thrust rod installation. 	Tighten Tighten
Power Trim & Tilt	<ul style="list-style-type: none"> ● Check working of the tilt up and down of the motor. 	
Cooling Water	<ul style="list-style-type: none"> ● Check that cooling water is discharged from the cooling water check port after the engine has started. 	
Tools and Spares	<ul style="list-style-type: none"> ● To be prepare tools and spare parts for replacing spark plugs, propeller, etc. ● Check if the spare rope is provided. 	
Steering Devices	<ul style="list-style-type: none"> ● Check working of steering handle and remote control. 	
Other parts	<ul style="list-style-type: none"> ● Check if the anode and trim tab are securely installed. ● Check the anode and trim tab for corrosion and deformation. 	Repair if necessary Replace

Washing with fresh water

When the engine has been used in salt water or polluted water, wash the exterior and flush the cooling passage with fresh water using the flushing attachment.

Screw the included flushing attachment into the wash hole on the gear case. Connect a water hose to the flushing attachment and flush out with water. (Be sure to secure the water inlet and sub-water inlet on the gear case beforehand.)

! CAUTION

Keep cooling water passage free of clogs, or lack of cooling water flow could lead to engine overheating, potentially resulting in engine trouble.

! WARNING

Do not start engine without removing propeller, or accidentally turning propeller could cause personal injury.

! WARNING

Never start or operate the engine indoors or in any space which is not well ventilated. Exhaust gas contains carbon monoxide, a colorless and odorless gas which can be fatal if inhaled for any length of time.

○ Notes

It is recommended to check chemical properties of water on which your outboard motor is regularly used.

Flushing attachment (Optional)

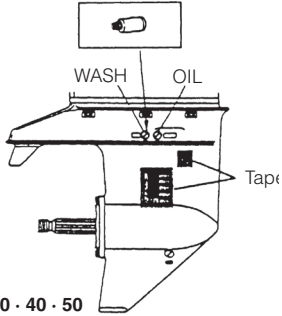

Flushing attachment (Optional)

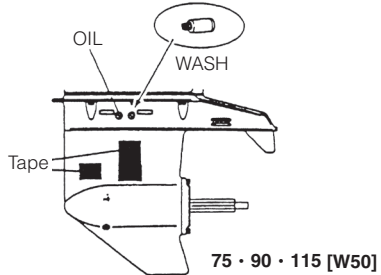

! CAUTION

Keep engine at idle speed during flushing.

Wash the engine before long-term storage.

Run the engine at low speed with the Remote Control lever (or Shift lever) set to Neutral to flush out fresh water from the cooling system and in the process remove salt, mud and other foreign particles.

■ Washing (continued)

(for 75 • 90 and 115 model)

- ⊙ Stand the engine upright. (Don't put the engine in the tilt-up condition.)
 - ⊙ Remove the flushing connector cap located in the left side of the bottom cowl.
 - ⊙ Install the flushing attachment (hose joint) supplied as an accessory to the flushing connector and then connect a rubber hose to the flushing attachment. Connect the other end of the rubber hose to a faucet (water tap) and turn on the faucet to wash the engine.
- * It is not required to run the engine during this washing.

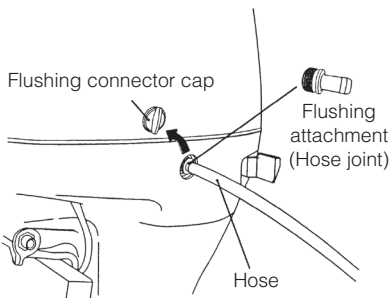

⚠ WARNING

Do not start engine without removing propeller, or accidentally turning propeller could cause personal injury.

⚠ CAUTION

Keep engine at idle speed during flushing.

Replacing the propeller

A worn-out or bent propeller will lower the motor's performance, and cause engine trouble.

Before removing the propeller, remove the spark plug caps from the spark plugs to protect against personal injury.

⚠ WARNING

Do not begin propeller removal and installation procedure with spark plug caps attached, shift in forward or reverse, main switch at other than "OFF", engine stop cord attached to the switch, and starter key attached, or engine could accidentally start leading to serious personal injury. Disconnect battery cable if possible.

- ① Pull out the split pin and remove the propeller nut and washer.
- ② Remove the propeller by pulling toward you.
- ③ Apply genuine grease to the propeller shaft before mounting the new propeller.
- ④ Fit the washer, securely tighten the nut and insert the split pin.

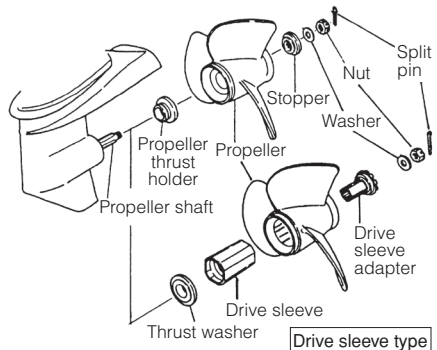

⚠ WARNING

Do not hold propeller with hand(s) when loosening or tightening propeller nut. Put a piece of wood block between propeller blade and anti-ventilation plate to hold propeller.

⚠ CAUTION

- Do not install propeller without thrust holder, or propeller boss could be damaged.
- Do not reuse split pin.
- After putting split pin, open the end to prevent it from coming off which could lead to coming off of propeller.

Replacing the spark plugs

⚠ WARNING

- Do not reuse spark plug with damaged insulation, or sparks can leak through crack, potentially leading to electric shock, explosion and/or fire.
- Do not touch spark plugs immediately after stopping engine as they will be hot and could cause severe burns if touched. Allow motor to cool down first.

○ Notes

When inspecting the plug, always clean the gasket surface and use a new gasket. Wipe off any dirt from the threads and screw in the spark plug to the correct torque.

If the spark plug(s) is fouled, has carbon build up, or is worn, it should be replaced.

When reusing spark plugs, remove dirt from the electrodes and adjust spark gap to specification.

- ① Remove the top cowl.
- ② Remove the spark plugs by turning counter-clockwise with the socket wrench (16mm: 5/8 in) fitted with the handle. Tap lightly on the spark plugs if they are hard to turn.

Use spark plug NGK IZFR6Q.

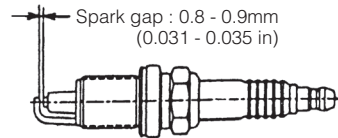

NGK IZFR6Q (30 · 40 · 50 · 75 · 90)
NGK IZFR5J (115)

○ Notes

- ◎ Spark plug torque :
18.0Nm(13.3ft-lb)(1.8kgf-m)
If a torque-wrench is not available when you are fitting a spark plug, a good estimate of the correct torque is 1/4 to 1/2 a turn past finger-tight. Have the spark plug adjusted to the correct torque as soon as possible with a torque-wrench.

⚠ CAUTION

Do not touch the high tension cords running from the ignition coil to the spark plugs while the engine is running or is turned by the electric starter motor, not even for testing the high tension cords or the spark plugs. The high tension cords and the spark plugs generate very high electric voltage, which can cause a serious electric shock if touched.

2. Periodic inspection

It is important to inspect and maintain your outboard motor regularly. At each interval on the chart below, be sure to perform the indicated servicing. Maintenance intervals should be determined according to the number of hours or number of months, whichever comes first.

For periodic inspection and maintenance, consult your servicing dealer.

Description		Inspection intervals				Inspection procedure	Remarks
		First 20 hours or 1 month	Every 50 hours or 3 months	Every 100 hours or 6 months	Every 200 hours or 1 years		
Fuel System/ Compression System	Fuel filter		○	○	Replace ○	Check and clean or Replace if necessary.	Entire cartridge
	High pressure fuel filter *1				Replace ○	Replace every 200 hrs or 2 years	
	Piping/Hoses *2	○	○	○	Replace ○	Check and clean or Replace if necessary	
	Fuel tank *2	○	○	○	○	Clean	Including filter
	Fuel tank cap *2	○	○	○	○	Check and clean or Replace if necessary.	
	Fuel pump *1	○	○	○	○	Check and clean or Replace if necessary.	
	Air filter			○	○	Check and clean or Replace if necessary.	
	Drive belt *1			○	○	Check and Replace if necessary.	
	Fuel Pressure *1			○	○	Check and replace defective parts if necessary.	
	Air Pressure *1			○	○	Check and replace defective parts if necessary.	
Ignition	Spark plug	○		○	○	Remove carbon deposits or Replace if necessary.	0.8-0.9mm (0.031-0.035in)
Starting System	Starter motor *1			○	○	Check for salt deposits and the battery cable condition.	
	Battery	○	○	○	○	Check installation, fluid quantity, gravity.	

*1 Have this handled by your dealer

*2 In USA, you have to use EPA approved part.
(See P36 - P37).

○ Notes

Your outboard motor should receive careful, and complete inspection at 300 hours. This is the best time for major maintenance procedures to be carried out.

Description		Inspection intervals				Inspection procedure	Remarks
		First 20 hours or 1 month	Every 50 hours or 3 months	Every 100 hours or 6 months	Every 200 hours or 1 years		
Engine oil system	Oil tank	<input type="radio"/>		<input type="radio"/>	<input type="radio"/>	Check and clean or Replace if necessary.	
	Oil pipe	<input type="radio"/>		<input type="radio"/>	<input type="radio"/>		
	Oil filter	<input type="radio"/>		<input type="radio"/>	<input type="radio"/>	Check and clean or Replace if necessary.	
Lower Unit*	Propeller	<input type="radio"/>	<input type="radio"/>	<input type="radio"/>	<input type="radio"/>	Check for bent blades, damage, wear.	
	Gear oil	Replace <input type="radio"/>		Replace <input type="radio"/>	Replace <input type="radio"/>	Change or replenish-oil and check for water leaks.	
	Water pump *1		<input type="radio"/>	<input type="radio"/>	<input type="radio"/>	Check for wear or damage.	Replace impeller every 12 months.
Thermostat *1				<input type="radio"/>	<input type="radio"/>	Check and Replace if necessary.	
Power tilt & trim *1		<input type="radio"/>		<input type="radio"/>	<input type="radio"/>	Check & replenish oil, manually operate	
Warning system *1			<input type="radio"/>	<input type="radio"/>	<input type="radio"/>	Check function	
Bolts and Nuts		<input type="radio"/>	<input type="radio"/>	<input type="radio"/>	<input type="radio"/>	Retighten	
Sliding and Rotating Parts. Grease Nipples		<input type="radio"/>	<input type="radio"/>	<input type="radio"/>	<input type="radio"/>	Apply and pump in grease.	
Outer Equipment		<input type="radio"/>	<input type="radio"/>	<input type="radio"/>	<input type="radio"/>	Check for corrosion.	
Anode			<input type="radio"/>	<input type="radio"/>	<input type="radio"/>	Check for corrosion and deformation.	Replace if necessary.

Replacing gear oil

⚠ WARNING

- Be sure that outboard motor is secured to transom or service stand, or accidental drop or fall of outboard motor could lead to severe personal injury.
- Be sure to lock outboard motor if it is tilted up, or accidental fall of outboard motor could lead to severe personal injury.
- Do not go under outboard motor tilted up and locked, or accidental fall of outboard motor could lead to severe personal injury.

- ① Remove the oil plugs (upper and lower), and completely drain the gear oil into a pan.

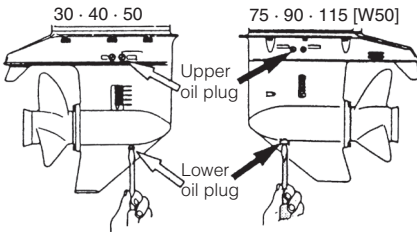

- ② Insert the oil tube nozzle into the lower oil plug hole, and fill with gear oil by squeezing the oil tube until oil flows out of the upper plug hole.

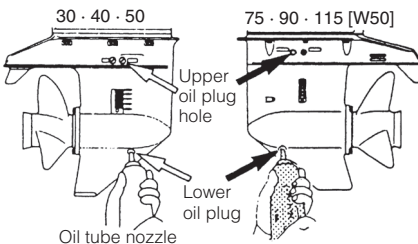

- ③ Install the upper oil plug, and then remove oil tube nozzle and install the lower oil plug.

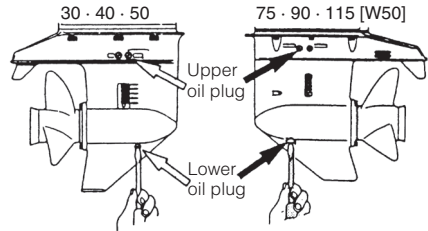
**⚠ CAUTION**

Do not reuse oil plug gasket. Always use new gasket and tighten oil plug properly to prevent entry of water into lower unit.

○ Notes

If water in the oil, giving it a milky colored appearance. Contact your dealer.

○ Notes

Use only genuine or recommended gear oil or, if not available, an API (American Petroleum Institute) oil grade of GL5 SAE #80~SAE#90.

Required volume

: 30, 40, 50 approx. 500mL (16.89 U.S. fluid oz)

: W50 approx. 700mL (23.65 U.S. fluid oz)

: 75, 90, 115 approx. 900mL (30.40 U.S. fluid oz)

Cleaning Tanks and Filters

⚠ WARNING

Gasoline and its vapors are very inflammable and can be explosive.

- Do not start this procedure while engine is operating or hot even after stopping it.
- Place fuel filter away from every source of ignition such as sparks or open flames.
- Wipe off gasoline well immediately if spilled.
- Install fuel filter with all related parts in place, or fuel leak could occur, leading to catching fire or explosion.
- Check fuel system regularly for leakage.
- Contact Tohatsu dealer for fuel system services. Services by unqualified person could lead to engine damage.

- Fuel filters are provided inside the fuel tank and on the engine. Loosen a Fuel Pick-up Elbow and remove it. Then clean the Fuel Filter.

- Cleaning Fuel Tank
Water or dirt in the fuel tank may cause engine trouble. Clean the tank at specified times or after long time storage (over three months).

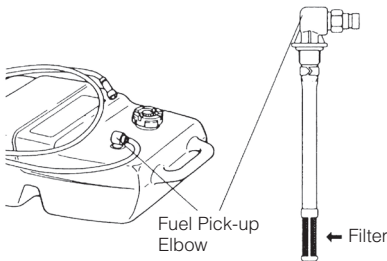

- Clean the filters on the engine after removing the fuel filter cases. If the red float is floating in the fuel filter, water is present. In such the case, immediately remove the cup and drain out the water.

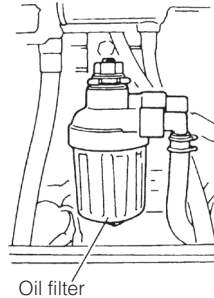
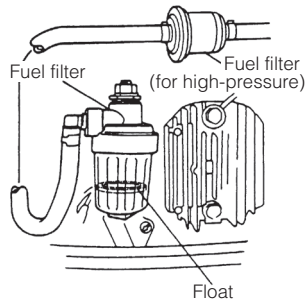

- Oil filter and oil tank. Check the oil tank and/or filter for entrapped water and dust.
 - ① Disconnect all pipes between the oil tank and oil pump.
 - ② Clean out foreign matter.
 - ③ Refit the pipes to the oil tank and pumps, and then fill up with new engine oil.
 - ④ For air purging, refer to Item No.5 Fuel and Engine Oil.

⚠ CAUTION

You may be injured due to high engine temperatures if you fill engine oil just after stopping. Changing engine oil should be done after the engine has been cooled.

⚠ CAUTION

- Do not overfill engine oil, or engine oil could leak and/or engine could be damaged. If engine oil level is over upper limit marks of oil gauge, drain oil to level lower than upper limit.
- Be sure that outboard motor is in upright and level position when checking or changing oil.
- Stop engine immediately if low oil pressure warning lamp is lit or oil leak is found, or engine could be severely damaged. Consult dealer.

○ Notes

- If any amount of water is found in engine oil, making it milky white, consult dealer.
- If engine oil is contaminated with fuel, emitting strong fuel smell, consult dealer.

Checking and Refilling Oil in the Power Trim & Tilt.

- ① Check the oil level of the reservoir tank as shown on the right while the tank is kept in a vertical position. Tilt the engine up to check the oil level in the tank. Remove the oil cap by turning counter-clockwise, then check if the oil level reaches the bottom line of the plug hole.

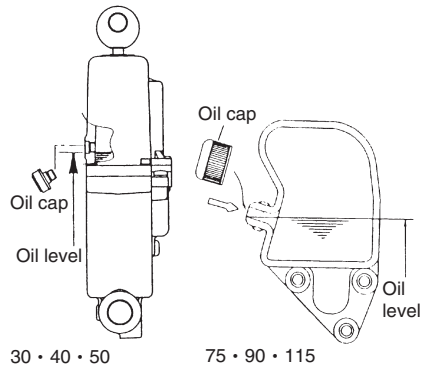
**⚠ WARNING**

- Be sure that outboard motor is secured to transom or service stand, or accidental drop or fall of outboard motor could lead to severe personal injury.
- Be sure to lock outboard motor if it is tilted up, or accidental fall of outboard motor could lead to severe personal injury.
- Do not go under outboard motor tilted up and locked, or accidental fall of outboard motor could lead to severe personal injury.

⚠ CAUTION

Do not fully unscrew the oil plug with the engine tilted down. Pressurized oil in the oil tank may spurt out.

- ② Recommended oil
Use an automatic transmission fluid or equivalent. Recommended oils are as shown below.
ATF Dexron III

- ③ Air purging from the Power Trim and Tilt unit.

Entrapped air in the Power Trim & Tilt unit will cause poor tilting movement. With the engine mounted on the boat, set the manual release valve to the Manual side, and tilt the engine manually up/down 5-6 times while checking the oil level. When done, close the valve by turning it clockwise towards the Power side.

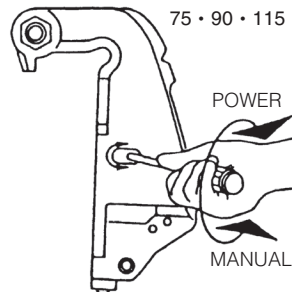
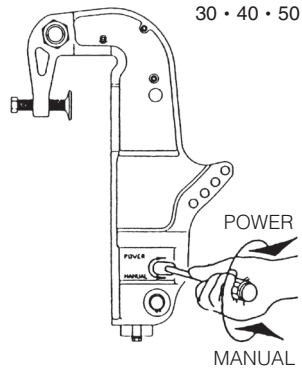

3. Off-season storage

WARNING

- When the motor is out of the water, being transported, or in storage, always remove the negative (-) battery cord to prevent accidental starting of the engine. Accidental starting when the motor is out of the water will cause water pump failure, overheating and damage to the engine due to a lack of cooling water.
- Remove all spark plug connectors from the spark plugs when servicing the engine or propeller.

When your outboard motor is in storage, this is a good opportunity to have it serviced or overhauled by your dealer.

■ Engine

- ① Wash the engine exterior and flush the cooling water system thoroughly with fresh water. Let the water drain completely.
Wipe off any surface water with an oily rag.
- ② Drain the fuel out of the fuel tank and clean the inside of the tank and fuel filter.
- ③ Clean the engine fuel filter.
- ④ Clean the oil filter.
- ⑤ Remove the spark plugs and feed genuine engine oil or storage fogging oil through the spark plug holes.
Turn the engine over several times while feeding the oil into it and make sure it is evenly distributed.

- ⑥ Apply grease to the propeller shaft.
- ⑦ Change the gear oil in the gear case.
- ⑧ Apply grease to all sliding parts, joints, nuts, and bolts.
- ⑨ Use a dry cloth to completely wipe off water and salt from the electrical components.
- ⑩ Stand the outboard motor up vertically in a dry place.

WARNING

Be sure to use cloth to remove fuel remaining in the cowl and dispose of it in accordance with local fire prevention and environment protection regulations.

■ Battery

- ① Disconnect the battery cords.
- ② Clean the exterior of the battery with fresh water or compressed air. Wipe off any chemical deposits, dirt and grease from the battery.
- ③ Apply grease to the battery terminals.
- ④ Charge the battery completely before storing it for the winter.
- ⑤ Recharge the battery once a month to prevent it from discharging and the electrolyte from deteriorating.
- ⑥ Store the battery in a dry place with its cover attached.

CAUTION

- Do not allow the battery to discharge, since it can be damaged by freezing.
- When storing your outboard for the winter, open up all the water drain holes in the gear case to permit any remaining water to drain out. If a speedometer is installed, disconnect the pickup tube and allow it to drain, then reconnect it after draining. Trapped water may crack the gear case or water pump case as a result of expansion when frozen. Check and replenish the gear case with case specified Gear Oil before storing the motor, to avoid water leakage into the gear case due to a loose lubricant vent plug or grease fill plug. Inspect the gaskets under the lubricant vent and grease plugs, replace them if necessary, and reinstall the plugs.

■ Electric Starter Motor

Coat the pinion gears and the shaft of the electric starter motor with grease.

4. Pre-season check

Have your dealer check the engine before the season starts, or if you prefer, be sure to check the following items yourself:

- ① Check the electrolyte level, and measure the voltage and specific gravity of the battery.

Specific Gravity at 20 °C	Terminal Voltage (V)	Charge Condition
1.120	10.5	Fully discharged
1.160	11.1	1/4 charged
1.210	11.7	1/2 charged
1.250	12.0	3/4 charged
1.280	13.2	Fully charged

- ② Check that the battery is secure and the battery cables are properly installed.
- ③ Clean the engine oil filter.
- ④ Purge air in the vinyl pipe connecting the oil tank to the oil pump.
- ⑤ Check that the shift and throttle function properly.
(Be sure to turn the propeller shaft when checking the shift function or else the shift linkage may be damaged.)
- ⑥ If the engine has been kept without running for a long time, the following operation is required before starting it.
- ◎ Air purging for oil line—Refer to Item No.5 Fuel and Engine Oil, Oil pump air vent.

- ◎ Forced fuel feeding—Refer to Item No.6 Running, 2 Starting.
- ◎ Forced engine oil feeding—Refer to the same as above.

5. Checking after striking underwater object

Striking sea bottom or underwater object may severely damage the outboard motor.

Immediately bring the outboard motor to your dealer and ask for the following checks.

- ① Looseness or damage of power unit installation bolts, gear case and extension case bolts, propeller or propeller shaft, upper and lower mount rubber bolts and nuts, power trim and tilt bolts, and mount rubber cap bolts.

Ask to tighten loose bolts and nuts, and to replace damaged parts.

- ② Deformation and damage of mount rubber, tilt stopper, thrust rod, gears and clutch, and propeller.

Ask to replace damaged or deformed parts.

6. If the engine becomes submerged in water

After pick up, immediately bring the outboard to your dealer.

Following are the emergency measures to be taken on the submerged outboard.

- ① Take it out of water immediately and wash it with fresh water to remove all traces of salt and dirt.
- ② After picking up the engine, ask the dealer to perform the necessary actions to make sure the engine is brought back to safe operating condition.

CAUTION

Do not attempt to start submerged outboard motor immediately after it is recovered, or engine could be severely damaged.

7. Precautions in cold weather

When morning in cold weather at sub-zero temperatures the water in the cooling water pump may freeze and severely damage the pump, impeller, and associated parts. To avoid this, submerge the lower half of the engine into the water, or tilt the engine and operate the electric starter motor for 5 seconds with the stop switch lock plate taken away to allow the water to drain completely.

■ TROUBLESHOOTING

If you encounter problem with the engine, check the list below and locate the problem you are experiencing. Then follow the suggested remedies.

Do not hesitate to contact your dealer, as professionals advice and assistance is the best way to keep the engine in optimum condition.

Difficult to start engine	Engine runs erratically	Boat speed loss	Battery will not hold charge	Starter motor will not crank	Power Trim & Tilt Inoperative	Possible causes
●						Empty fuel tank
●	●					Incorrect connection of fuel system
●	●					Air enters fuel line
●	●					Deformed or damaged fuel pipe
●						Closed air vent on fuel tank cap
●	●					Fuel filter/fuel pump is clogged with dust.
●						Use of improper gasoline
●						Incomplete forced fuel feeling by primer bulb
●	●					Poor connection in compression system
●	●					Use of non-specified spark plugs
●	●					Dirt or carbon deposits on spark plugs
●	●					No sparking or poor sparking (Failure in component of Ignition system)
	●					Insufficient cooling water flow

Difficult to start engine	Engine runs erratically	Boat speed loss	Battery will not hold charge	Starter motor will not crank	Power Trim & Tilt Inoperative	Possible causes
	●	●				Propeller cavitation
		●				Incorrect propeller selection
	●	●				Damaged or bent propeller
		●				Unbalanced loading. Overload
		●				Transom is too high/low.
		●				Bottom of the boat is stained or damaged.
●		●				Insufficient throttle aperture.
				●	●	Battery is charged insufficiently.
●			●	●	●	Battery is nearly dead, Poor connection of battery terminal, Low level of electrolyte
					●	Power trim & tilt switch is defective.
●				●		Wrong positioning of shift lever at N (neutral) position.
●			●	●	●	Main switch in defective.
●						Lock plate is not inserted or poorly inserted into stop switch.
●			●	●	●	Wrong wiring, disconnection, poor connection.
●				●		Faulty operation of starter motor/starter solenoid
					●	A great deal of air is contained inside pump.

TOOL KIT AND SPARE PARTS

30 , 40 , 50

The following a list of the tools and spare parts provided with the motor.

Name		Quantity	Remark
Servicing Tools	Tool Bag	1	Adapter-type
	Socket Wrench (16mm)	1	
	Socket Wrench (10 × 13)	1	
	Socket Wrench Handle	1	
	Pliers	1	
	Screwdriver (Phillips-type and flat head)	1	
Spare Parts	Rope (1,600mm)	1	NGK IZFR6Q Diameter × Length 3 × 25mm
	Spark Plug	3	
	Split Pin	1	
Parts Packaged with Engine *	Bracket Fixing Bolts	4	12mm
	Bracket Fixing Nuts	4	12mm
	Washers A, B	4 each	A (large), B (small)
	Fuel Tank (with primer bulb)	1] for EPTO
	Remote Control Box	1	
	Drag Link	1	
	Tachometer	1	
	Trim meter	1	
Lead Wire for Meter	1		

※ Not included as standard accessories in some markets.

75 , 90 ,115

The following a list of the tools and spare parts provided with the motor.

Name		Quantity		Remark
		MD 75/90	MD 115	
Servicing Tools	Tool Bag	1	1	Adapter-type
	Socket Wrench (16mm)	1	1	
	Socket Wrench (10 × 13)	1	1	
	Socket Wrench Handle	1	1	
	Pliers	1	1	
	Screwdriver (Phillips-type and flat head)	1	1	
Spare Parts	Spark Plug (75/90)	3		NGK IZFR6Q
	Spark Plug (115)		4	NGK IZFR5J
	Split Pin		1	Diameter×Length 3 × 25mm
Parts Packaged with Engine *	Bracket Fixing Bolts		4	12mm
	Bracket Fixing Nuts		4	12mm
	Washers A, B		4 each	A (large), B (small)
	Drag link		1	
	Flushing attachment (Hose joint)		1	For washing
	Primer bulb ass'y	1	1	

※ Fuel tank, remote control box, tachometer, trim meter, meter lead wire and propeller are not enclosed in the engine package.

OPTIONAL ACCESSORIES

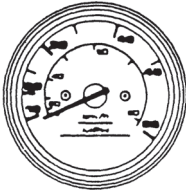

Speedometer
(50MPH)

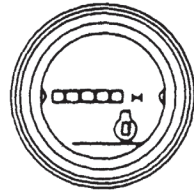

Hour Meter
(engine operation hour counter)



Speedometer
(75MPH)

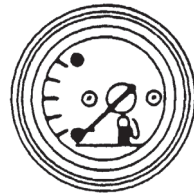

Fuel Meter

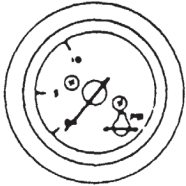

Water Pressure Meter

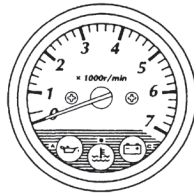

Tachometer



Voltmeter



Flushing attachment

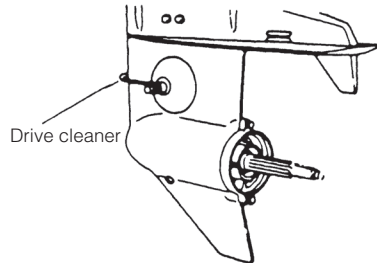

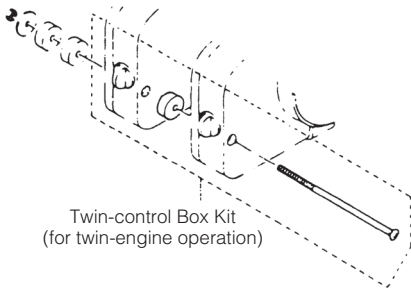

Twin-control Box Kit
(for twin-engine operation)

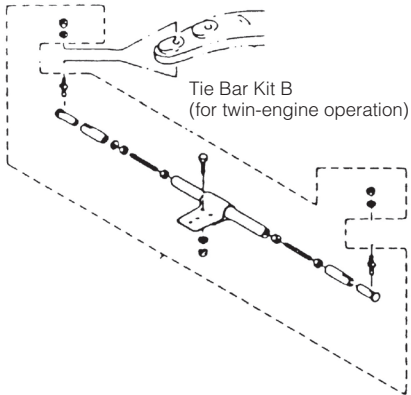

Tie Bar Kit B
(for twin-engine operation)



Propeller

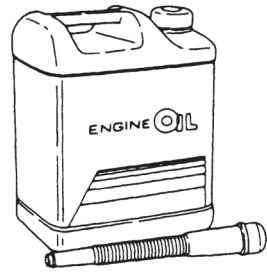

Engine oil (4l)

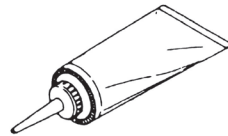

Genuine gear oil (500ml)



Touch-up Spray Paint

PROPELLER TABLE

To ensure optimum performance, the propeller should match the boat type and its load.

Use a genuine propeller.

A propeller must be selected so that the engine rpm measured at wide open throttle, while cruising, is within the recommended range.

5, 150 to 5,850 rpm

30 • 40 • 50

	Mark
Lighter Load Heavier Load	CS15
	CS14
	CS13
	CS12
	CS11
	CS9
	※7

※ shows propeller with four blades.

W50

	Mark
Lighter Load Heavier Load	17.5
	16.5
	15
	14
	13
	12
	11
	10
	9

75 • 90

	Mark
Lighter Load Heavier Load	M-21
	M-19
	M-17
	M-16
	M-15
	M-13
	M-11

※ The 75, 90 model is supplied with so standard propeller. It is shipped from the factory without a propeller.

※115

	Mark
Lighter Load Heavier Load	M-21
	M-19
	M-17
	M-16
	M-15
	M-13
	M-11

※ The 115 model is supplied with so standard propeller. It is shipped from the factory without a propeller.

MEMO

A series of horizontal dashed lines for writing.

OWNER'S MANUAL

MD 30B2

40B2

50B2

75C2

90C2

115A2

TOHATSU CORPORATION

Address : 5-4, 3-chome, Azusawa, Itabashi-ku,
TOKYO, 174-0051 JAPAN

Phone : TOKYO (03)3966-3117

FAX : TOKYO (03)3966-2951

URL : www.tohatsu.co.jp